

# Customer Care Solutions

## RH-19 Cellular Phone

# 7 - RF Description and Troubleshooting

## Table of Contents

Description	Page No.
RF Description and Trouble Shooting .....	5
Introduction .....	5
RF Key Component Placement .....	6
RF Test points .....	7
Receiver .....	7
Transmitter .....	8
Synthesizer .....	8
RF in General .....	9
RF Power Supply configuration .....	11
General Specifications of Transceiver RH-19 .....	12
Receiver Description and Trouble Shooting .....	13
General instructions for RX Trouble Shooting .....	13
Measuring RX I/O signals using RSSI reading .....	13
Measuring RX Performance using SNR measurement .....	14
Measuring Front-end Power Levels using Spectrum Analyzer .....	16
Measuring Analogue RX I/Q signals using Oscilloscope .....	16
Fault finding chart for receiver .....	17
RX Signal paths .....	18
Antenna switch (RX/TX switch) .....	19
RX Front-end .....	19
RX Paths of Mjoelner RF ASIC .....	19
Transmitter Description and Trouble Shooting .....	20
General instructions for TX Trouble Shooting .....	20
TX signal paths .....	20
Antenna switch (TX/RX switch) .....	22
EGSM (EGSM900) Transmitter .....	22
General instructions for EGSM900 TX Trouble Shooting .....	22
Fault Finding Chart for EGSM900 TX .....	24
GSM1800 (DCS/PCN) Transmitter .....	25
General Instructions for GSM1800 TX Trouble Shooting .....	25
Fault finding chart for GSM1800 TX .....	27
GSM1900 (PCS) Transmitter .....	28
General Instructions for GSM1900 TX Trouble Shooting .....	28
Fault finding chart for GSM1900 TX .....	28
Synthesizer Description and Trouble Shooting .....	30
General instructions for Synthesizer Trouble Shooting .....	30
Check synthesizer operation .....	30
26MHz reference oscillator (VCXO) .....	31
VCO .....	32
Fault finding chart for PLL Synthesizer .....	32
Frequency lists .....	34
EGSM900 .....	34
GSM1800 .....	35
GSM1900 .....	36

Description	Page No.
DC Supply Current Check .....	37
RF Tuning Instructions .....	38
General Instructions for RF Tuning .....	38
RF tuning after Repairs .....	38
RX Calibration .....	38
RX Calibration EGSM900 .....	39
RX Calibration GSM1800 (DCS/PCN) .....	42
RX Calibration GSM1900 (PCS) .....	44
RX Band Filter Response Compensation .....	47
RX Band Filter Response EGSM900 (EGSM) .....	47
RX Band Filter Response GSM1800 (DCS/PCN) .....	50
RX Band Filter Response GSM1900 (PCS) .....	52
RX Channel Select Filter Calibration .....	55
RX AM Suppression (not needed) .....	56
TX Power Level Tuning .....	56
TX Power Level Tuning EGSM (EGSM900) .....	57
TX Power Level Tuning GSM1800 (DCS/PCN) .....	59
TX Power Level Tuning GSM1900 (PCS) .....	60
TX I/Q tuning .....	62
TX I/Q Tuning GSM900 .....	62
TX I/Q Tuning GSM1800 .....	66
TX I/Q Tuning GSM1900 .....	70

List of Figures

Figure 1	RF key components placement .....	6
Figure 2	Test points of the RX .....	7
Figure 3	Test points of the TX .....	8
Figure 4	Test points of the Synthesizer .....	8
Figure 5	RF frequency plan .....	9
Figure 6	RF block diagram .....	10
Figure 7	RF power distribution diagram .....	11
Figure 8	RX signal paths .....	18
Figure 9	TX signal paths .....	21
Figure 10	PLL Synthesizer Fault Finding Chart.....	32
Figure 11	PLL block diagram .....	33

Appendices

A	FLAL1 Test Cases .....	7A-1/6
B	FinUI Test Cases .....	7B-1/6
C	Component Placement with Test Points & Detailed Descriptions .....	7C-1/6

**This page has been intentionally left blank**

## RF Description and Troubleshooting

### Introduction

The sections below provide instructions how to check, repair and calibrate the RF section of RH-19 phones.

It is assumed that for tuning and repair the phones are disassembled and tested within a repair jig MJS-52.

The following types of measurements can be done for diagnosis and repair of RH-19 phone modules:

- RF measurements shall be done using a Spectrum Analyzer together with a high-frequency probe. (Note, that signal will be significantly attenuated). Correct attenuation can be checked using a "good" phone board for example.
- LF (Low frequency) and DC measurements shall be done with a an oscilloscope together with a 10:1 probe.
- For receiver measurements a signal generator with frequencies up to 2000 MHz is required. Most of the radio communication testers like CMD55 or CMU200 can be used as signal generator. The signal generator is connected to the antenna port using the repair jig MJS-52.
- Output level measurements of the transmitter shall be done with a power meter, which is connected to the antenna port using the repair jig MJS-52.

Always make sure that the measurement set-up is calibrated when measuring RF parameters at the antenna port. Remember to include the correct losses of the module repair jig (as stated on MJS-52) and the connecting cable when realigning the phone.

Most RF semiconductors are static discharge sensitive. ESD protection must be used during repair (wrist straps and ESD proof soldering irons).

Mjoelner RF ASIC is moisture sensitive. Therefore, Mjoelner RF ASIC must be in appropriate condition or pre-baked prior to soldering.

RX calibration done via Phoenix software is temperature sensitive because of calibration of the 26 MHz reference oscillator (VCXO). According to Mjoelner specification ambient temperature has to be in a range from 22°C to 36°C.

Apart from key-components described in the following sections there are a lot of discrete components (resistors, inductors and capacitors) for which trouble shooting is done by checking its proper soldering and complete assembly on the PWB. Capacitors and resistors can be checked by means of an ohm-meter, but be aware: in-circuit measurement results have to be evaluated carefully.

Note: In this document there are example measurements being depicted with Phoenix 2.50 pictures. This version of Phoenix however, is not the latest version.

Note: There are two different kinds of VCOs applicable (FDK and Matsushita).

Note: There are two different kinds of PAs applicable (Agilent and Hitachi).

Below the following abbreviations can be used interchangeably:

EGSM and EGSM900 to refer to GSM low band.

DCS or PCN or GSM1800 GSM medium band.

PCS and GSM1900 GSM high band.

## RF Key Component Placement

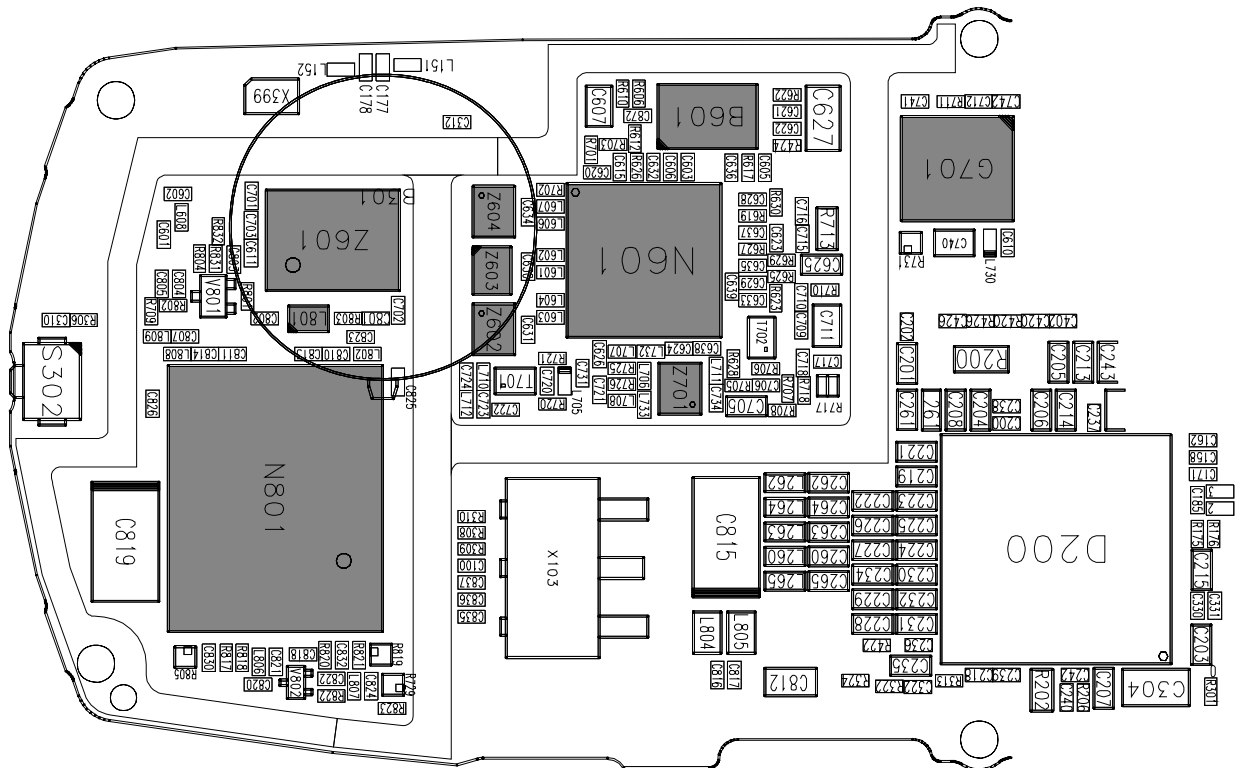

Figure 1: RF key components placement

Position	Component Name	Supplier and Description	Code
N801	TX-PA	Agilent, QCPM8893 Hitachi, PF08125B-03	4350369 4350409
L801	Directional Coupler	Murata, LDC15D190A0010A	4551015
Z601	Antenna Switch Module	Hitachi Metals, SHS-L090	4510385
Z602	SAW1800 RX	Epcos, B7714	4511313
Z603	SAW1900 RX	Epcos, B7720	4511367
Z604	SAW900 RX	Epcos, B7710	4511279
Z701	SAW900 TX	Epcos, B7715	4511311
N601	Mjoelner	Infineon, F3a	4370867
B601	XTAL	NDK	4510337
G701	VCO	FDK, IT016 Matsushita, ENFVJW2S05	4350315 435B036

### RF Test Points

The RF power supplies are generated in the UEM and can be measured either in the Mjoelner chamber or in the base band chamber. On the following illustration small circles show the locations of the test points.

#### Receiver

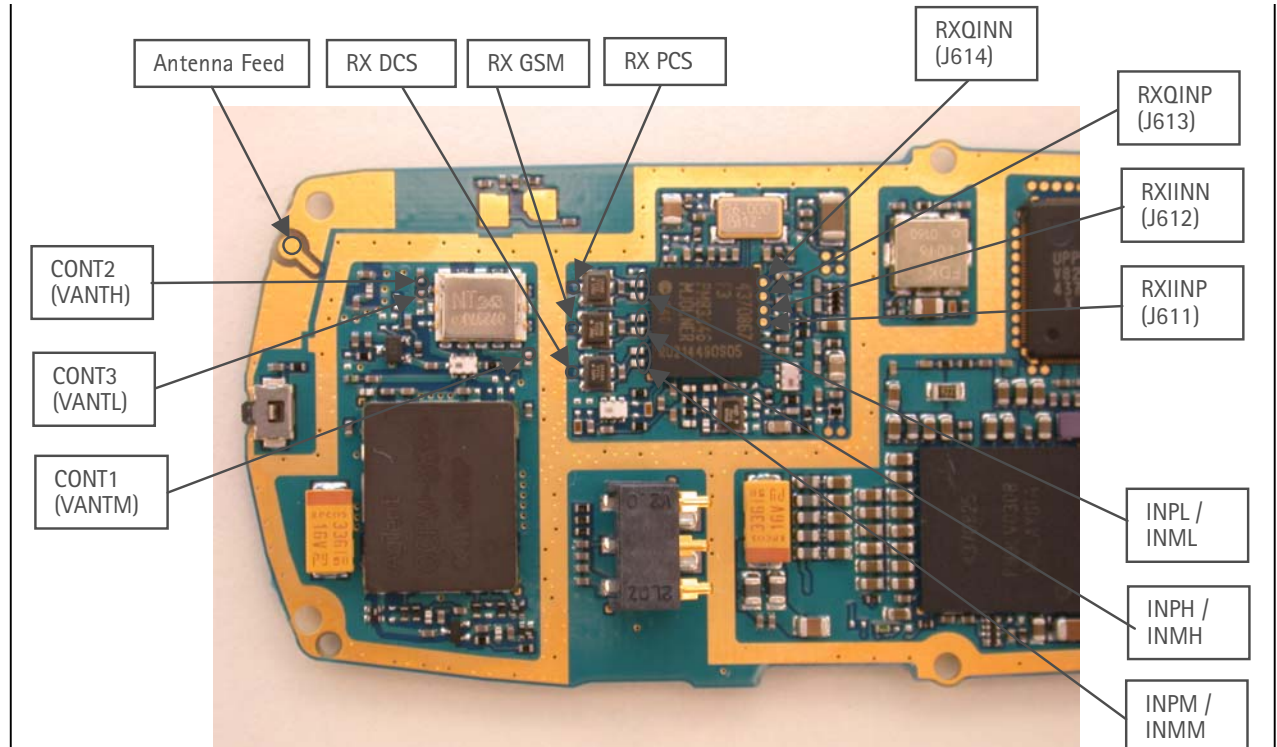

Figure 2: Test points of the receiver

**Transmitter**

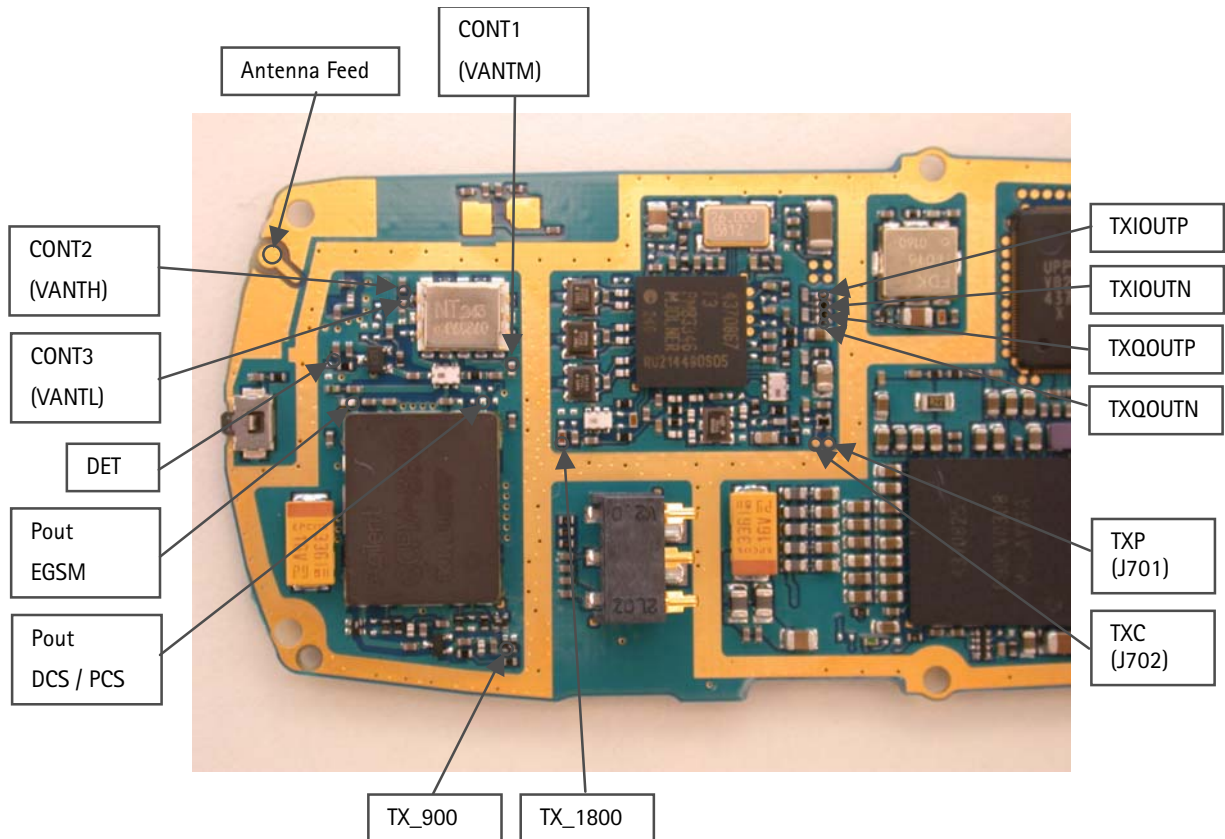

Figure 3: Test points of the transmitter

**Synthesizer**

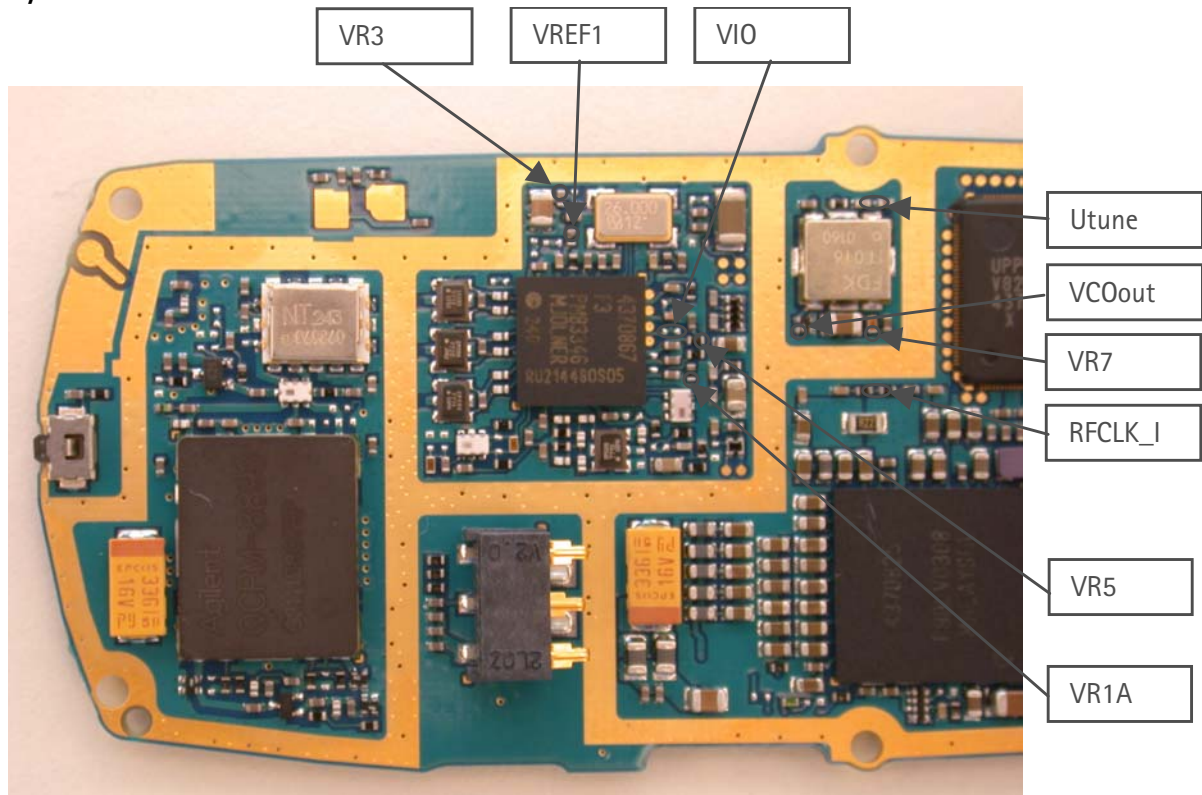

Figure 4: Test points of the synthesizer



## RF in General

The RH-19 RF front-end is a triple-band direct conversion transceiver. Using direct conversion, no intermediate frequencies are used for up- or down-conversion.

The VCO oscillates on the double respectively quadruplicate frequency of the wanted RX or TX frequency, depending on the band used. The VCO frequency is divided by either 2 or 4 and fed to the mixers (down-conversion) or modulators (up-conversion). Up- or down-conversion is done in one step, directly between RF frequency and base band. All up- and down-conversion takes place in the RF ASIC named Mjoelner (N601).

Mjoelner RF ASIC also contains PLL and LNAs for all used bands. A DC control section is included to power and/or control EGSM TX buffer, detector and antenna switch. The Mjoelner RF ASIC is controlled via a serial bus.

Mjoelner RF ASIC contains an integrated VCXO which uses an external 26 MHz Xtal. No analogue AFC signal is needed. AFC is realized via the serial interface port of Mjoelner.

The UPP is supplied by the 26 MHz reference clock of Mjoelner.

The phone supports HSCSD (High Speed Circuit Switched Data) and GPRS (General Packed Radio Service), meaning multi-slot operation. (This does not require special equipment or procedures in repair situations.)

The following diagrams show the RF frequency scheme and the RF block diagram.

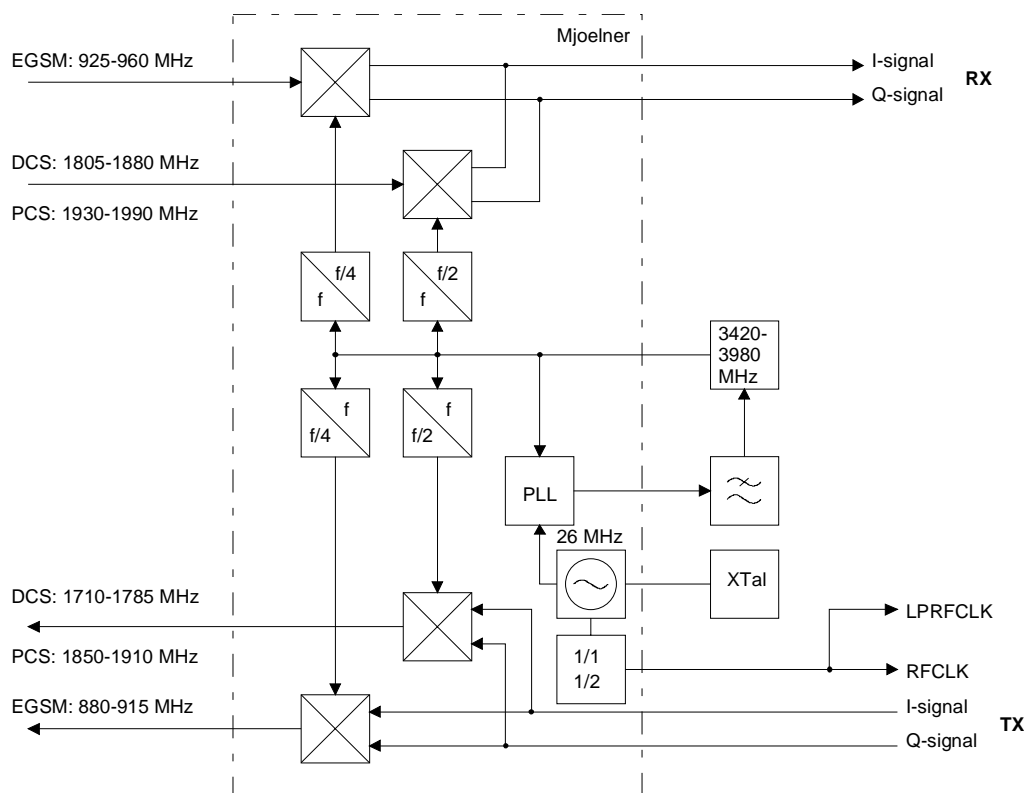

Figure 5: RF frequency plan



### RF Power Supply Configuration

All power supplies for the RH-19 RF Unit are generated in the UEM IC (D200). All RF supplies can be checked either in Mjoelner or in BB chamber.

The power supply configuration used is shown in the block diagram below. Values of voltages are given as nominal outputs of UEM. Currents are typical values.

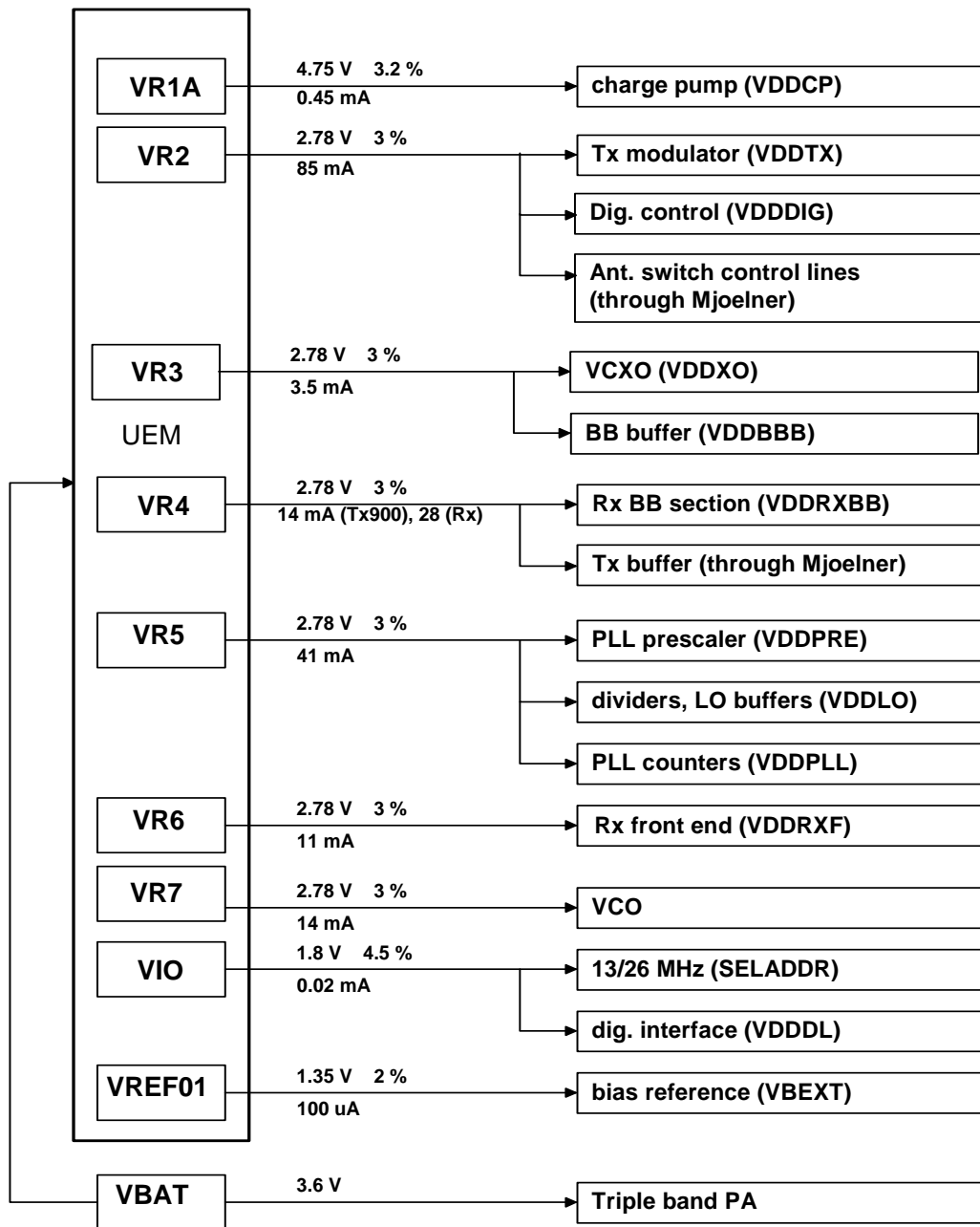

Figure 7: RF Power distribution diagram

## General Specifications of Transceiver RH-19

Parameter	Unit
Cellular System	GSM900, GSM1800, GSM1900
RX Frequency Band	EGSM: 925 ... 935 MHz GSM900: 935 ... 960 MHz GSM1800: 1805 ... 1880 MHz GSM1900: 1930 ... 1990 MHz
TX Frequency Band	EGSM: 880 ... 890 MHz GSM900: 890 ... 915 MHz GSM1800: 1710 ... 1785 MHz GSM1900: 1850 ... 1910 MHz
Output Power	EGSM: +5 ... +33 dBm (3.2 mW ... 2 W) GSM900: +5 ... +33 dBm (3.2 mW ... 2 W) GSM1800: +0 ... +30 dBm (1.0 mW ... 1 W) GSM1900: +0 ... +30 dBm (1.0 mW ... 1 W)
Duplex Spacing	EGSM: 45 MHz GSM900: 45 MHz GSM1800: 95 MHz GSM1900: 80 MHz
Number of RF Channels	EGSM: 50 GSM900: 124 GSM1800: 374 GSM1900: 299
Channel Spacing	200 kHz (each band)
Number of TX Power Levels	EGSM: 15 GSM900: 15 GSM1800: 16 GSM1900: 16
Sensitivity, static channel	EGSM: -102 dBm GSM900: -102 dBm GSM1800: -102 dBm (+25°C) GSM1900: -102 dBm
Frequency Error, static channel	< 0.1 ppm
RMS Phase Error	< 5.0 °
Peak Phase Error	< 20.0 °

# Receiver Description and Trouble Shooting

## General Instructions for RX Trouble Shooting

Connect the phone to a PC with dongle and DAU-9T cable (RS232) or DKU-5 cable (USB). Follow the instructions below.

Connect the phone to a power supply (DC voltage of 3.6V) and a RF signal generator.

## Measuring RX I/Q Signals using RSSI Reading

Start Phoenix Service Software and open FBUS connection.

Select Scan Product Ctrl-R

Wait until phone information is shown in the lower right corner of the screen.

Set operating mode to local mode

Select Maintenance Alt-M  
Testing T  
RF Controls F

Wait until the RF Controls window has popped up

Select Band GSM 900 or GSM1800 or GSM1900  
Active unit RX  
Operation mode **Burst**  
RX/TX Channel 37 or 700 or 661

Select Maintenance Alt-M  
Testing T  
RSSI reading R

The setup should now look like this:

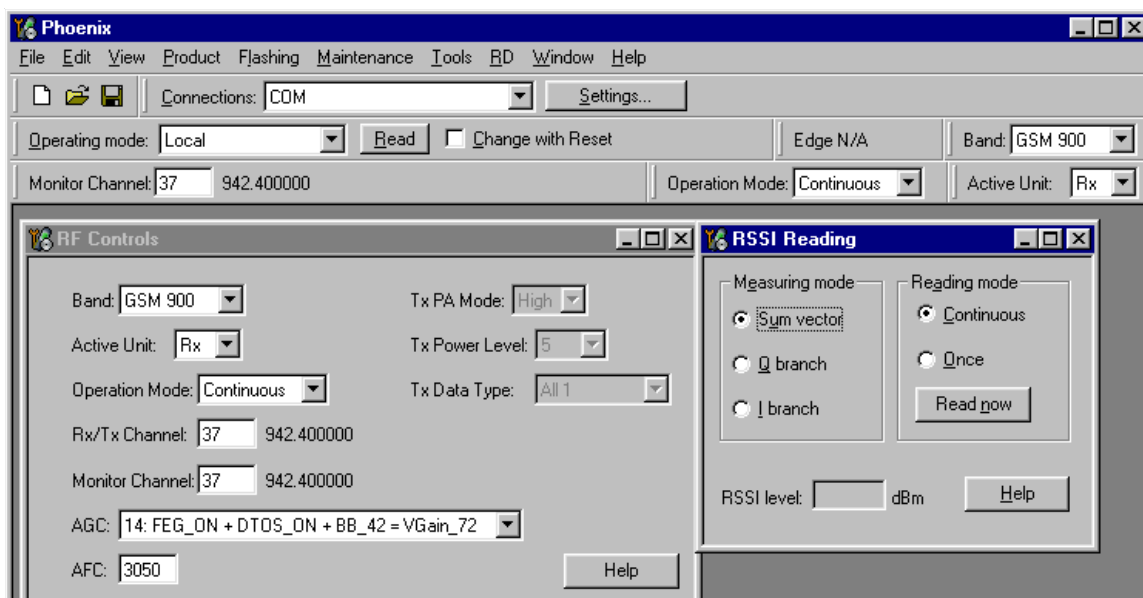

Make the following settings on your signal generator:

1. Frequencies:
  - EGSM: 942.46771 MHz (channel 37 + 67.710 kHz offset)
  - GSM1800: 1842.86771 MHz (channel 700 + 67.710 kHz offset)
  - GSM1900: 1960.06771 MHz (channel 661 + 67.710 kHz offset)
2. RF power level:
  - – **80dBm** at the antenna connector of the phone/test jig (remembering to compensate for the cable and jig attenuation).

In RSSI reading click on Read now.

The resulting RSSI level should be – 80dBm  $\pm$  0.5dB in each band.

### Measuring RX Performance using SNR Measurement

Start Phoenix Service Software and open FBUS connection.

Select Scan Product Ctrl-R

Wait until phone information is shown in the lower right corner of the screen.

Set operating mode to local mode.

Select Maintenance Alt-M  
Testing T  
RF Controls F

Wait until the RF Controls window has popped up.

Select Band GSM 900 or GSM1800 or GSM1900  
Active unit RX  
Operation mode **Burst**  
RX/TX Channel 37 or 700 or 661

Select Maintenance Alt-M  
Testing T  
SNR Measurement M

Select Fast SNR (Radio Button)

The setup should now look like this:

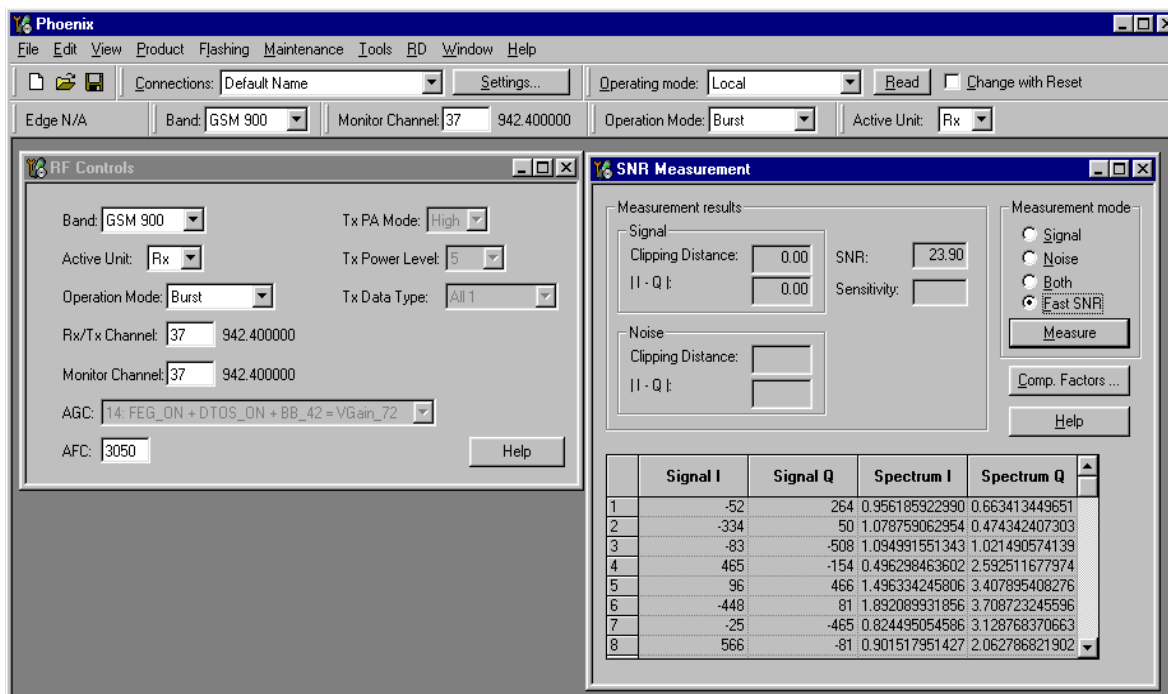

Choose respective band (EGSM900, GSM1800, GSM1900).

Press measure. A window pops up, e.g. for EGSM900 band:

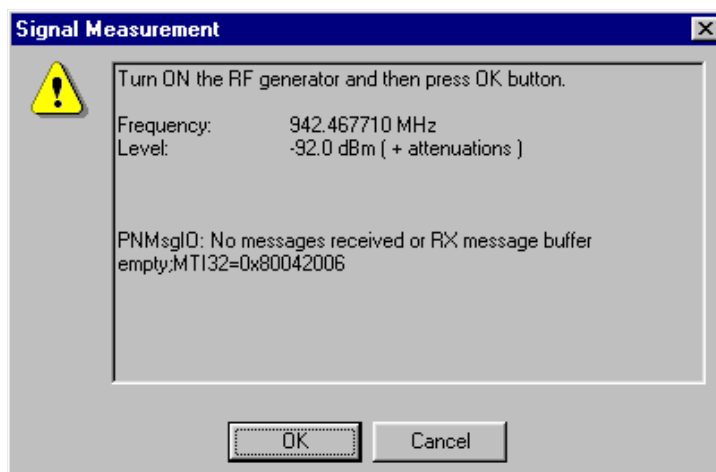

Set the signal generator as shown in the above window, remembering to compensate for the cable and test jig attenuation losses.

Press OK and the window closes.

Read the SNR result. The values should be:

- EGM900 ---->20dB
- GSM1800 ---->18dB
- GSM1900 ---->18dB

**Measuring Front-End Power Levels using Spectrum Analyzer**

Spectrum Analyzer (SA) level values depend on the probe type and should be validated using a good sample. The levels that are given here are measured using a resistive probe (500ohm semi-rigid cable).

Start Phoenix Service Software and open FBUS connection.

Select                      Scan Product                      Ctrl-R

Wait until phone information is showing in the lower right corner of the screen.

Set operating mode to local mode.

Select                      Maintenance                      Alt-M  
    Testing                      T  
    RF Controls                      F

Wait until the RF Controls window pops up

Select                      Band                      GSM 900 or GSM1800 or GSM1900  
    Active unit                      RX  
    Operation mode                      **Continuous**  
    RX/TX Channel                      37 or 700 or 661

Please refer to the fault finding chart for proper levels at different test points.

**Measuring Analogue RX I/Q Signals using Oscilloscope**

Measuring with an oscilloscope on "RXIINN" or "RXQINN" is recommended only if RSSI reading does not provide enough information. There exist dedicated test points for RX I and Q signals. Input level = -80dBm.

Start Phoenix Service Software and open FBUS connection.

Select                      Scan Product                      Ctrl-R

Wait until phone information is showing in the lower right corner of the screen.

Set operating mode to local mode.

Select                      Maintenance                      Alt-M  
    Testing                      T  
    RF Controls                      F

Wait until the RF Controls window has popped up.

Select                      Band                      GSM 900 or GSM1800 or GSM1900  
    Active unit                      RX  
    Operation mode                      **continuous**  
    RX/TX Channel                      37 or 700 or 661  
    AGC                      14

Following picture should be displayed on an oscilloscope's screen if the EGSM receiver is



working properly:

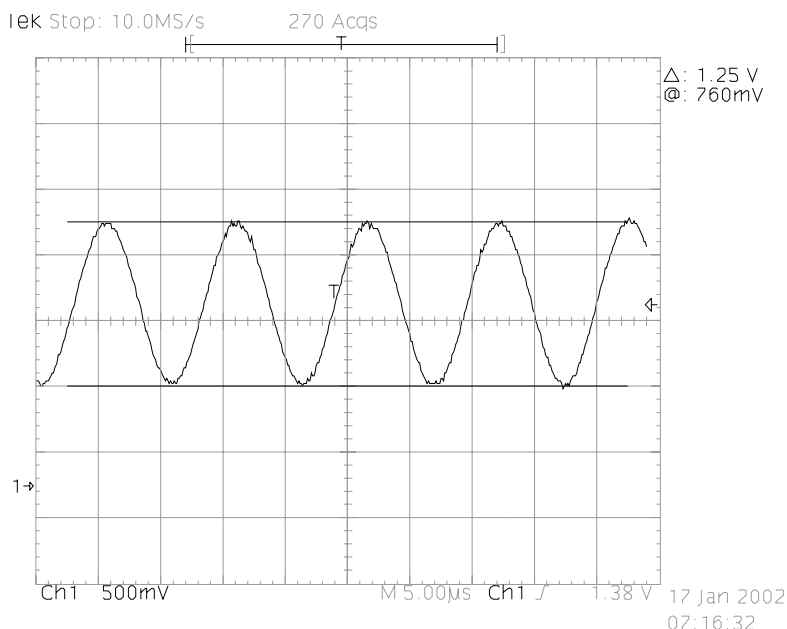

Signal amplitude	1.25V
DC offset	1.35V
Frequency	67kHz

### Fault Finding Chart of the Receiver

The phone layout has dedicated test points for the analogue differential RX I and Q signals (RXIINP, RXIINN, RXQINP, RXQINN) from Mjoelner RF ASIC to UEM. The BB part is used to measure those signals by means of RSSI reading. It is assumed that correct calibration of RSSI reading has been carried out in production.

$$RSSI_{reading} [dBm] = 20\log(U_{BB}) + AGC_{calibrated}$$

**Therefore, don't calibrate a defective phone before the phone error has been found.**

When a defective phone has been calibrated, a possible error in RX front-end might be masked. In that case one can get a reasonable RSSI reading, although the front-end shows excessive losses.

If it is not sure that **incorrect re-calibration** has been made, the following steps shall be done:

- Check if AGC calibration is within limits
- Check if SNR reading is o.k.  
Use an Oscilloscope to check levels of "RXIINN" and "RXQINN".

If RX and TX path seem to be faulty it has to be checked if the synthesizer is working. If yes, then check the path from the antenna pad J615 to the antenna switch Z601 (see

RX fault finding "Check RXTX switch").

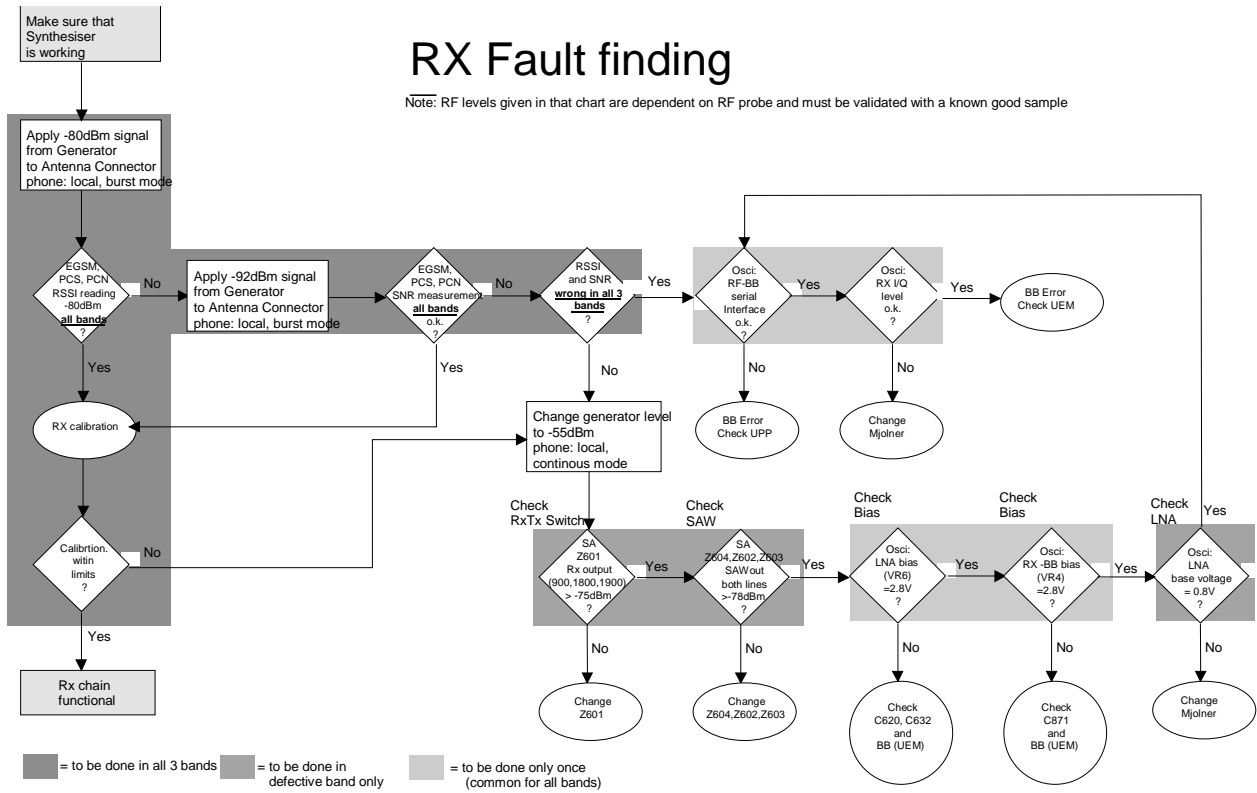

## RX Signal Paths

The signal paths of the receiver are shown in following block diagram. Note that the diagram shows EGSM900 receiver (above), GSM1900 receiver (middle) and GSM1800 receiver (below).

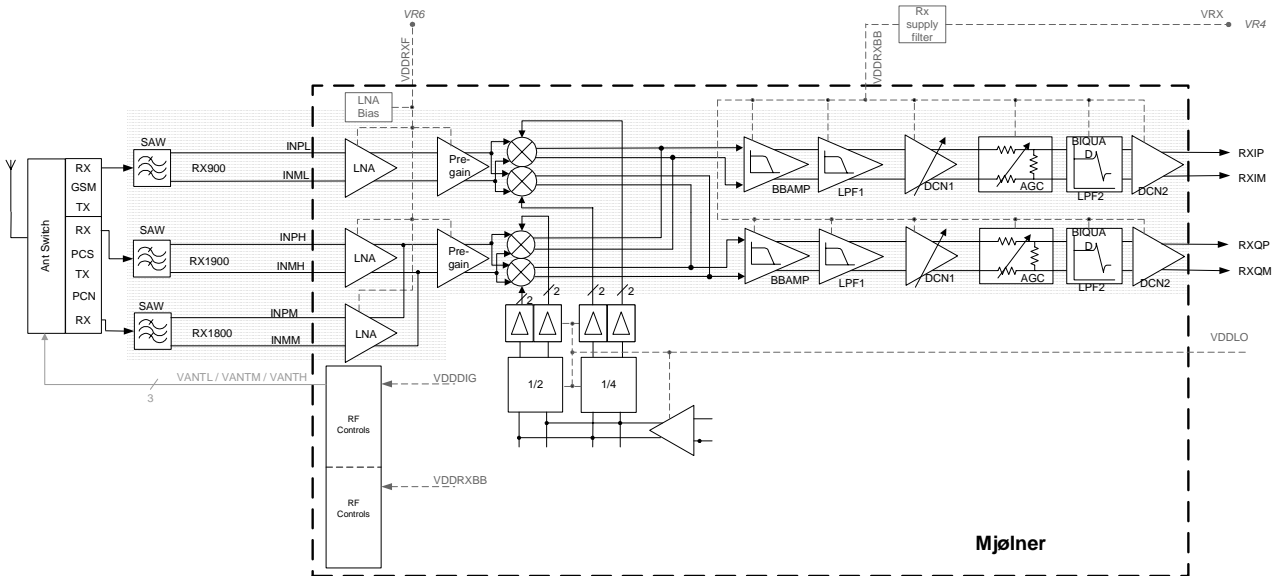

Figure 8: RX signal paths

### Antenna Switch (RX/TX Switch)

Signal path of RF: From the antenna-pad (J615) the RF signal is fed through the antenna low pass filter (C601, L608, C602) to the antenna switch (Z601).

The antenna switch has the function of a diplexer which consists of two paths, a GSM900 and a combined GSM1800/GSM1900. The EGSM900 input signals pass the switch to the GSM\_RX output. GSM1800/GSM1900 input signals pass to PCN\_RX output or respectively to PCS\_RX output, depending on the control signal VANTH (Cont2).

Signal paths:

- GSM900: RX1-GSM output of the antenna switch → EGSM900 SAW filter (Z604).
- GSM1800: RX2-DCS output of the antenna switch → GSM1800 SAW filter (Z602).
- GSM1900: RX3-PCS output of the antenna switch → RX GSM1900 SAW filter (Z603).

The antenna switch including routed lines has following typical insertion losses:

- EGSM900: 1.3dB
- GSM1800: 1.6dB
- GSM1900: 1.6dB

### RX Front-End

The RX front-end includes three SAW filters for EGSM900 (Z604), GSM1800 (Z602) and GSM1900 (Z603). They are matched to the corresponding LNA inputs of Mjoelner RF ASIC (N601) with differential matching circuits (LC-type). The SAW filters provide out-of-band blocking immunity. The integrated LNAs provide the front-end gains. Each of the SAW filters has a single-ended input and a balanced output.

The SAW filters have maximum insertion losses of

- EGSM900: 3.5dB
- GSM1800: 4.0dB
- GSM1900: 4.0dB

### RX Paths of Mjoelner RF ASIC

The balanced RX signal is amplified by the integrated LNA and the subsequent pre-gain stage. After amplification the RX signal is down-converted.

The RX paths of Mjoelner RF ASIC consist of following sub units:

- Separate LNAs for each of the three bands: EGSM900, GSM1800 and GSM1900.
- Two PRE-GAIN amplifiers, one for EGSM900 and one common for GSM1800 and GSM1900.
- Two passive I/Q mixers (MIX), one for EGSM900 and one common for GSM1800 and GSM1900.

The BB signal paths consist of:

- Base band amplifiers (BBAMP1). These amplifiers implement the initial channel filtering.
- Low pass filters (LPF1).
- DC compensation / AGC amplifiers (DCN1). These amplifiers implement gain steps from 0dB to 24dB in 6dB steps.
- Attenuators (AGC). These implement gain steps from -48dB to 0dB in 6dB steps, yielding a total gain range of 72dB together with DCN1.
- Bi-quad filters (LPF2).
- DC compensation amplifiers (DCN2).

The differential base band outputs are internally DC-coupled and are connected directly to the ADC inputs of the UEM-ASIC. The common mode level is set equal to the VBEXT reference voltage.

## Transmitter Description and Troubleshooting

### General Instructions for TX Troubleshooting

Connect a RF cable between the test jig and the measurement equipment (GSM test equipment, power meter, spectrum analyzer, or similar).

Make use of an adequate attenuator at the input of the measurement equipment (10dB to 20dB are recommended for a spectrum analyzer or a power meter). Assure not to overload or damage the equipment.

- 1 Connect the phone to a PC with DAU-9T cable (RS232) or DKU-5 cable (USB) and dongle.
- 2 Provide the phone with power supply (3.6V).
- 3 Start Phoenix Service Software and open FBUS connection.
- 4 Select Scan Product Ctrl-R  
and wait until phone information is shown in the lower right corner of the screen.

Follow the instructions as given below.

### TX Signal Paths

For easy error tracking it is important to know the signal paths of the transmitter. The components are grouped in blocks and shown on the diagram below.

Note: that the diagram shows both EGSM900 transmitter (below) and GSM1800/GSM1900 transmitter (above).

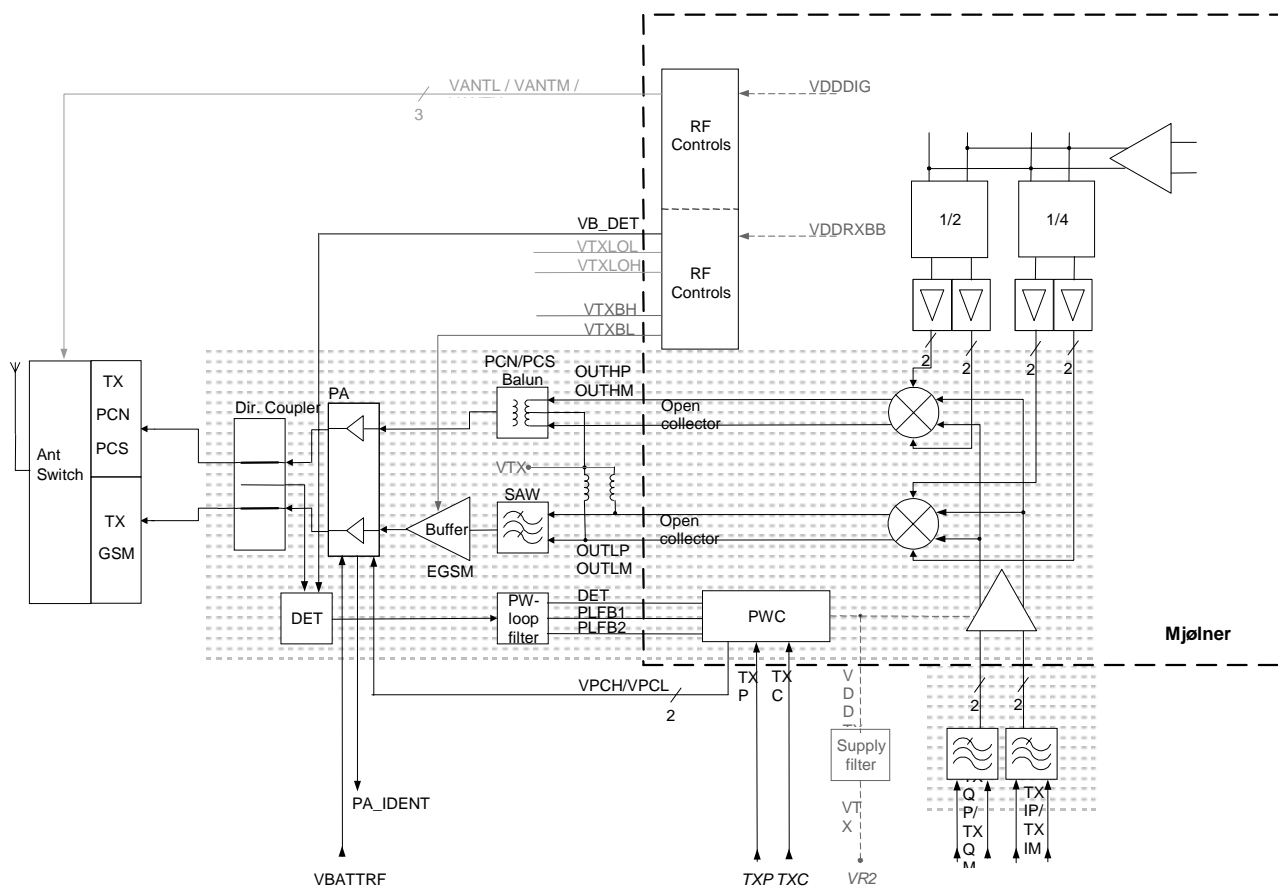

Figure 9: Transmitter signal paths

The balanced TX IQ baseband signals (TXIOUTP, TXIOUTN, TXQOUTP, TXQOUTN) are provided by the base band and are fed to the **Mjølner RF ASIC**. The TX path of the Mjølner RF ASIC includes mainly two RF modulators for up-conversion of the base band signals, one for EGSM900 and one common for GSM1800/GSM1900. The base band signal is up-converted with the LO signal corresponding to the wanted TX channel. Both RF-TX outputs (900MHz and 1800/1900MHz) of the Mjølner RF ASIC are delivering balanced signals.

The **EGSM900** output signal of the Mjølner RF ASIC is fed through the **EGSM TX SAW filter** (balanced to single ended), a 3dB pad, and the **900MHz buffer** to the EGSM input of the **power amplifier (PA)**.

The **GSM1800/1900** output signal of the Mjølner RF ASIC is fed through the **TX balun** (T701) (balanced to single ended), and a 3dB pad to the GSM1800/1900 input of the **power amplifier (PA)**.

The Triband PA has a maximum output power of approx. 35dBm at 900MHz and 33dBm at 1800/1900MHz. DC-power supply is delivered directly from the battery connectors.

The RF output power is controlled by the power control loop. From the output of the PA both signal are going through the dual directional coupler (one of the power control loop components) to the **antenna switch**.

**Note:** that there are two different kinds of PAs applicable (from Agilent and Hitachi).

### Antenna Switch (TX/RX switch)

The antenna switch operates as a diplexer for the RX and TX signals. Moreover, it suppresses the TX harmonics generated by the PA. The antenna switch is controlled by the Mjoelner RF ASIC using the control signals CONT1, CONT2 and CONT3.

The following table shows the possible different states.

CONT1 [Volt]	CONT2 [Volt]	CONT3 [Volt]	EGSM RX	DCS RX	PCS RX	EGSM TX	DCS/PCS TX
0	0	0	X				
0	0	0		X			
0	0	2.7				X	
0	2.7	0			X		X
2.7	2.7	0					X

To switch the TX-DCS/PCS path both signals cont1 and cont2 are activated. This increases the isolation from the TX-DCS/PCS path to the RX-DCS path and reduces the RF-power that is fed back to Mjoelner.

## EGSM (EGSM900) Transmitter

### General Instructions for EGSM900 TX Trouble shooting

Start the preparations as described in section "General Instructions for TX Trouble shooting".

Set operating mode to local mode.

Select Maintenance Testing RF Controls

Wait until the RF Controls window has popped up

Select	Band	GSM 900
	Active unit	TX
	Operation mode	Burst
	RX/TX Channel	37
	TX PA Mode	Free
	TX Power Level	10
	TX Data Type	Random

The setup should now look like this:

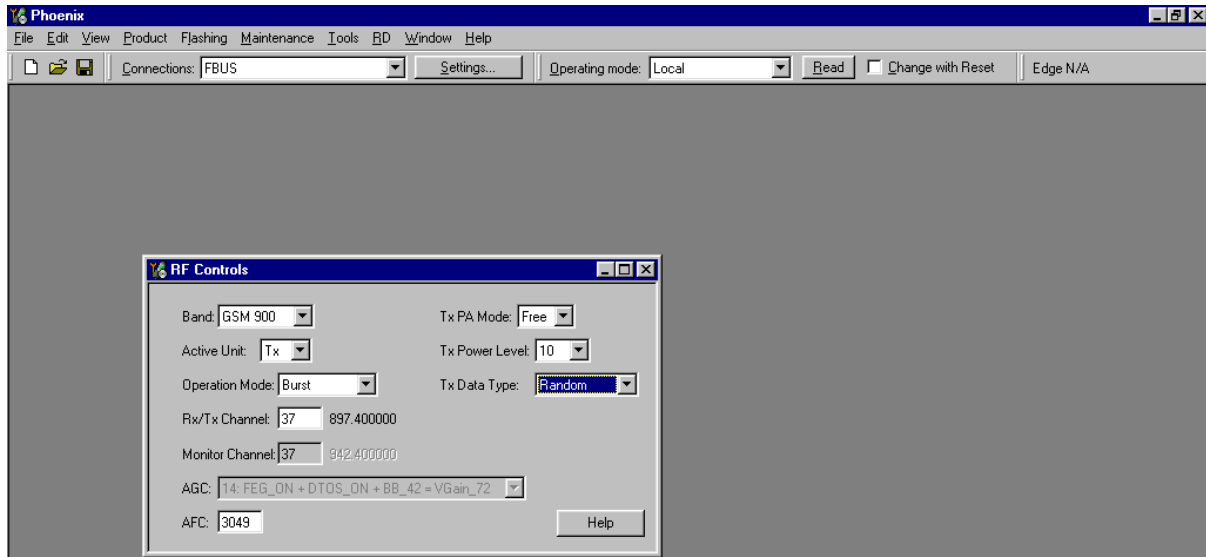

Now the measurement equipment should detect the following output signal of the phone:

$$P_{out} = +23dBm @ 897.4MHz$$

If this is not the case, then go to the following fault finding chart.

### Fault Finding Chart for EGSM900 Transmitter

In the following, the TXP signal is used as a trigger-signal. For this purpose a TXP test point is provided on the PWP, refer to figure 3.

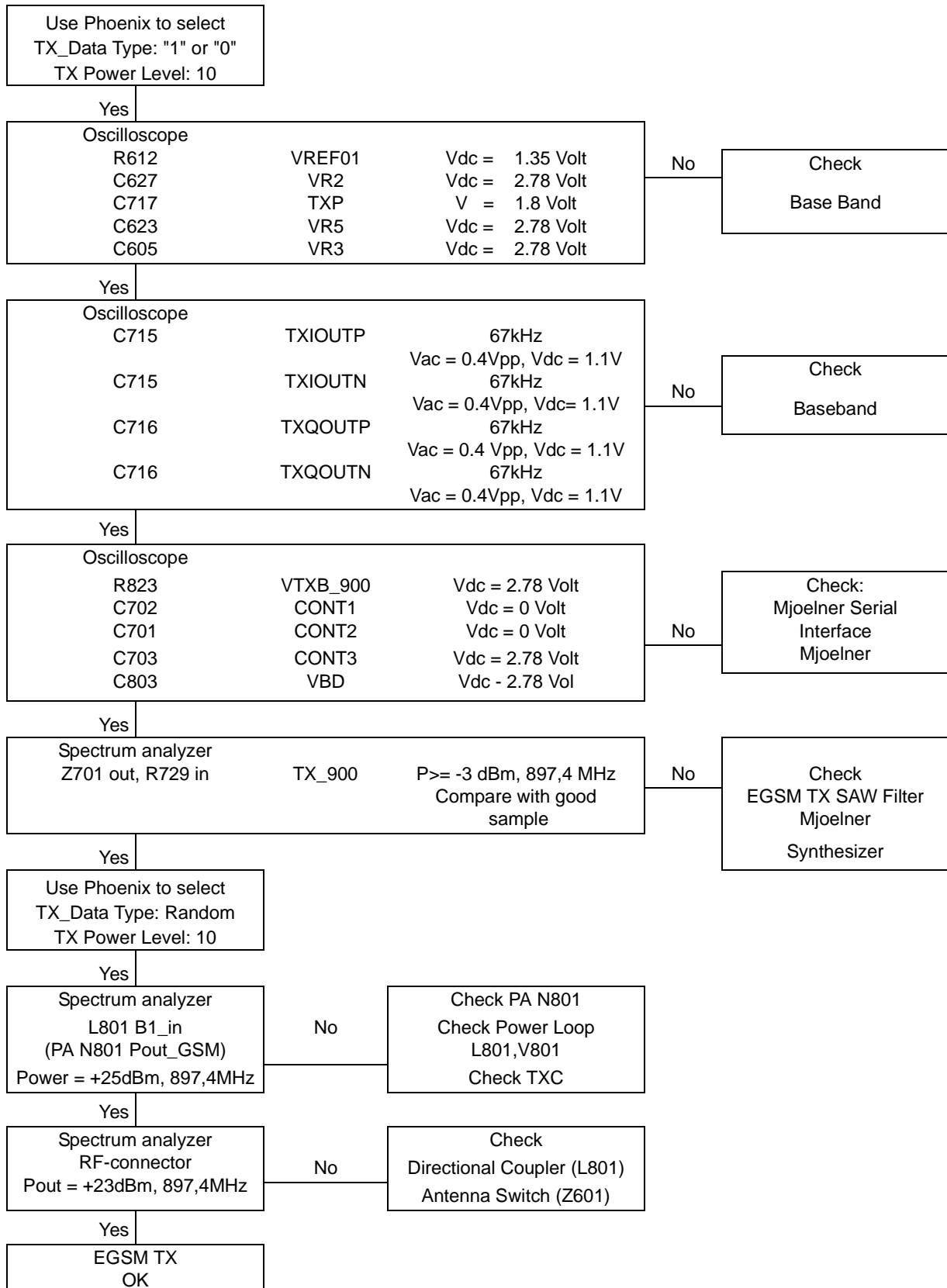



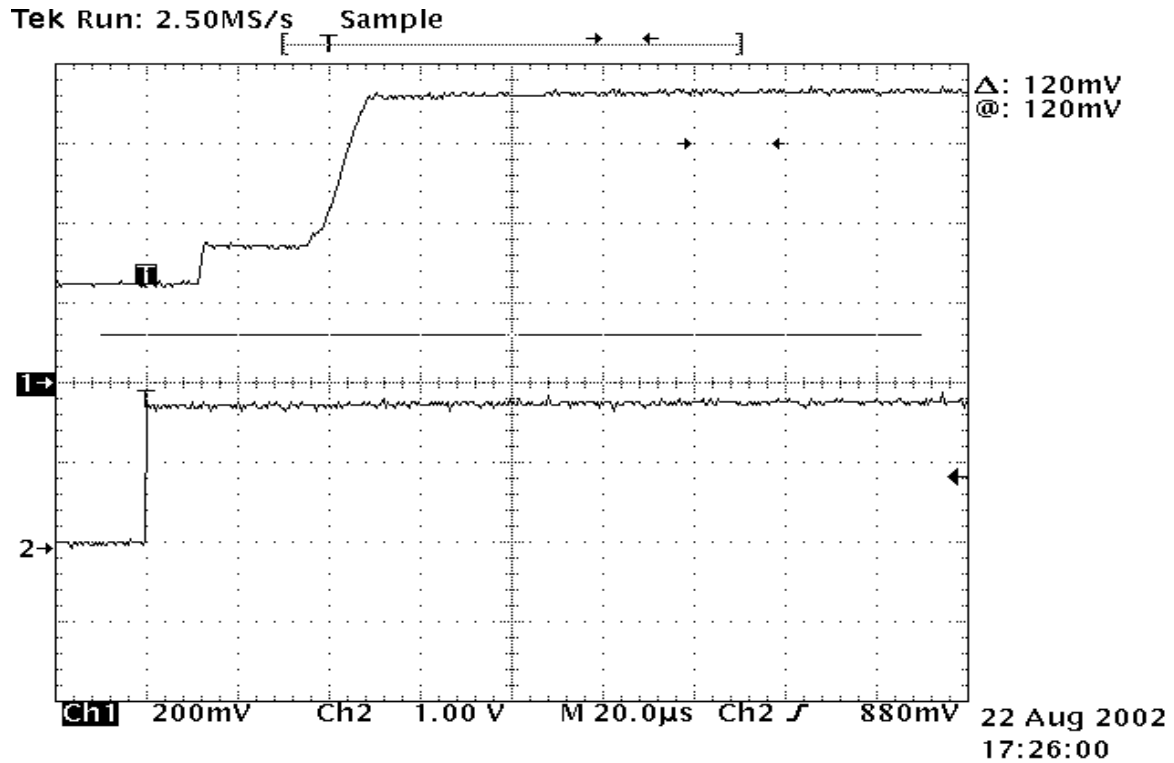

### GSM1800 (DCS/PCN) Transmitter

#### General instructions for GSM1800 TX Trouble shooting

Start the preparations as described in section "General Instructions for TX Trouble shooting".

Set operating mode to local mode.

Select Maintenance Testing RF Controls

Wait until the RF Controls window pops up.

Select	Band	GSM 1800
	Active unit	TX
	Operation mode	Burst
	RX/TX Channel	700
	TX PA Mode	Free
	TX Power Level	5
	TX Data Type	Random

The setup should now look like this:

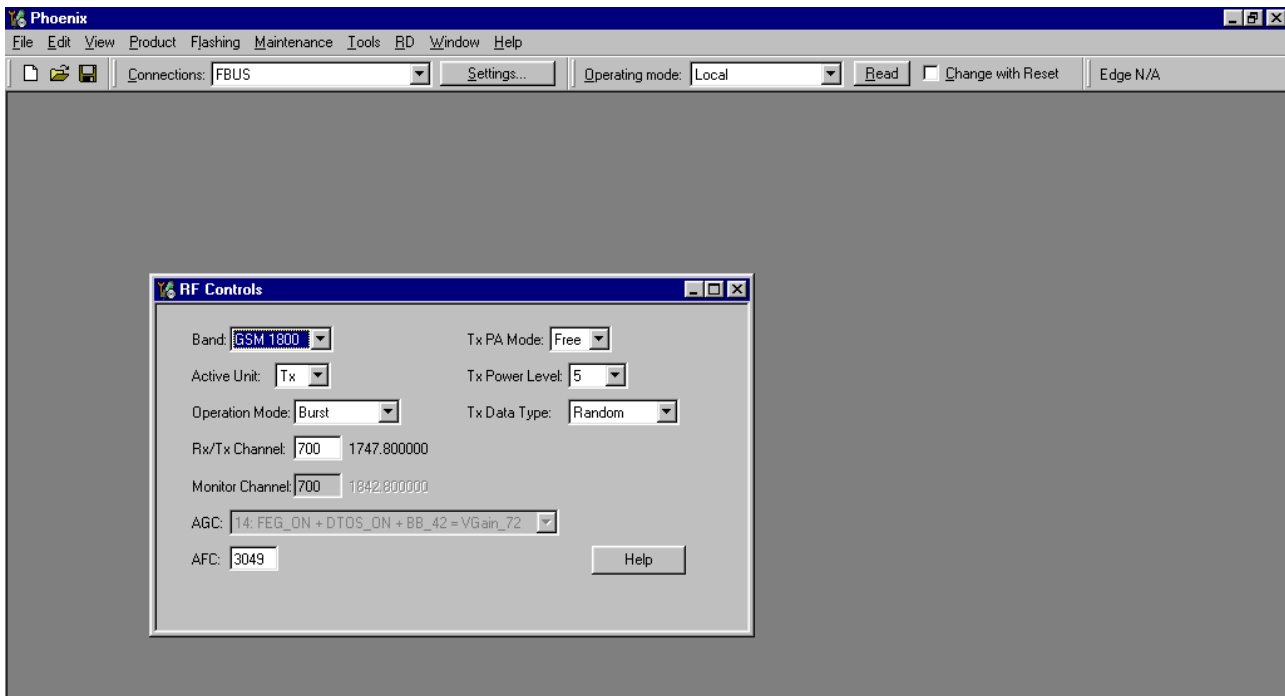

Now the measurement equipment should detect the following output signal of the phone.

$$P_{\text{out}} = +20\text{dBm @ } 1747.8\text{MHz}$$

If this is not the case, then go to the following fault finding chart.

**Fault finding chart for GSM1800 transmitter**

In the following, the TXP signal is used as a trigger-signal. For this purpose a TXP test point is provided on the PWP, refer to figure 3.

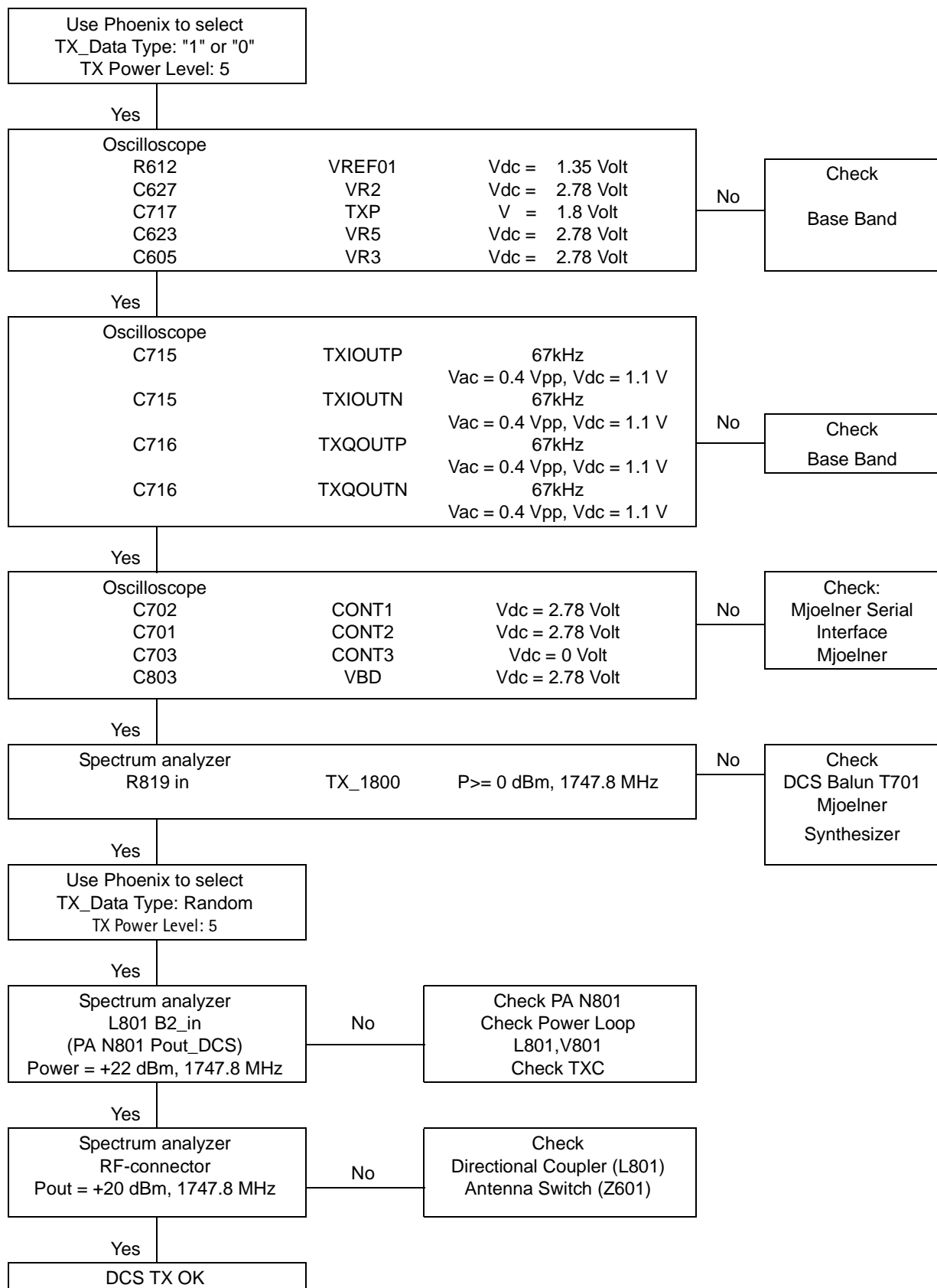

## GSM1900 (PCS) Transmitter

### General instructions for GSM1900 TX Trouble shooting

Start the preparations as described in section "General Instructions for TX Trouble shooting".

Set operating mode to local mode.

Select Maintenance Testing RF Controls

Wait until the RF Controls window pops up

Select	Band	GSM 1900
	Active unit	TX
	Operation mode	Burst
	RX/TX Channel	661
	TX PA Mode	Free
	TX Power Level	5
	TX Data Type	Random

The setup should now look like this:

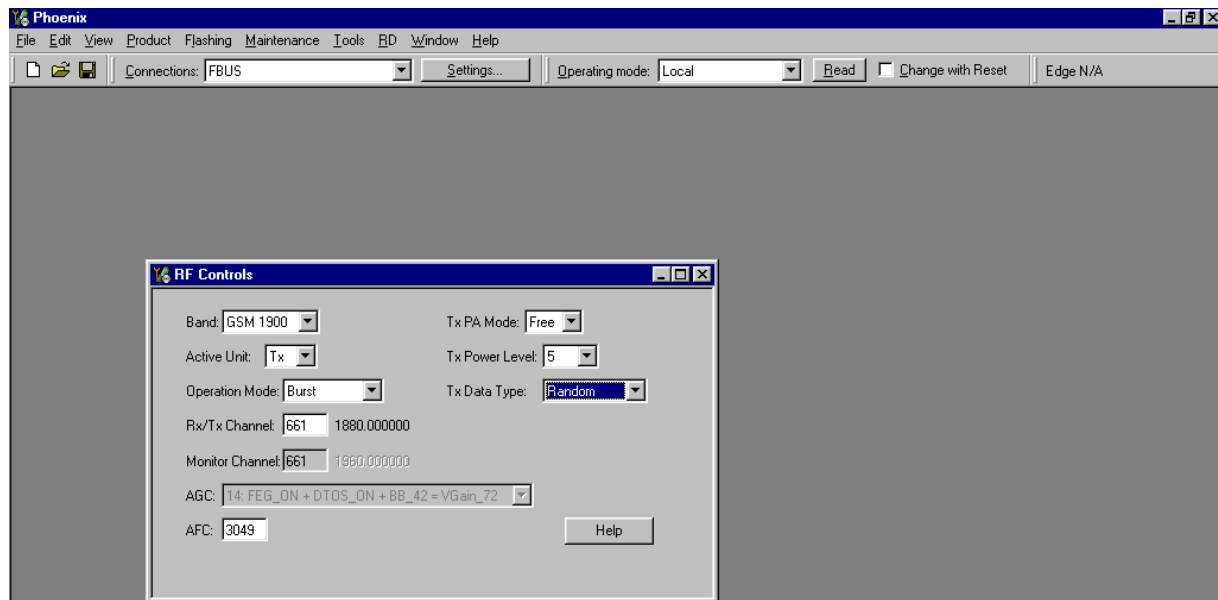

Now the measurement equipment should detect the following output signal of the phone.

$$P_{out} = +20\text{dBm @ } 1880\text{MHz}$$

If this is not the case, then go to the following fault finding chart.

### Fault finding chart for GSM1900 transmitter

In the following, the TXP signal is used as a trigger-signal. For this purpose a TXP test point is provided on the PWP, refer to figure 3.

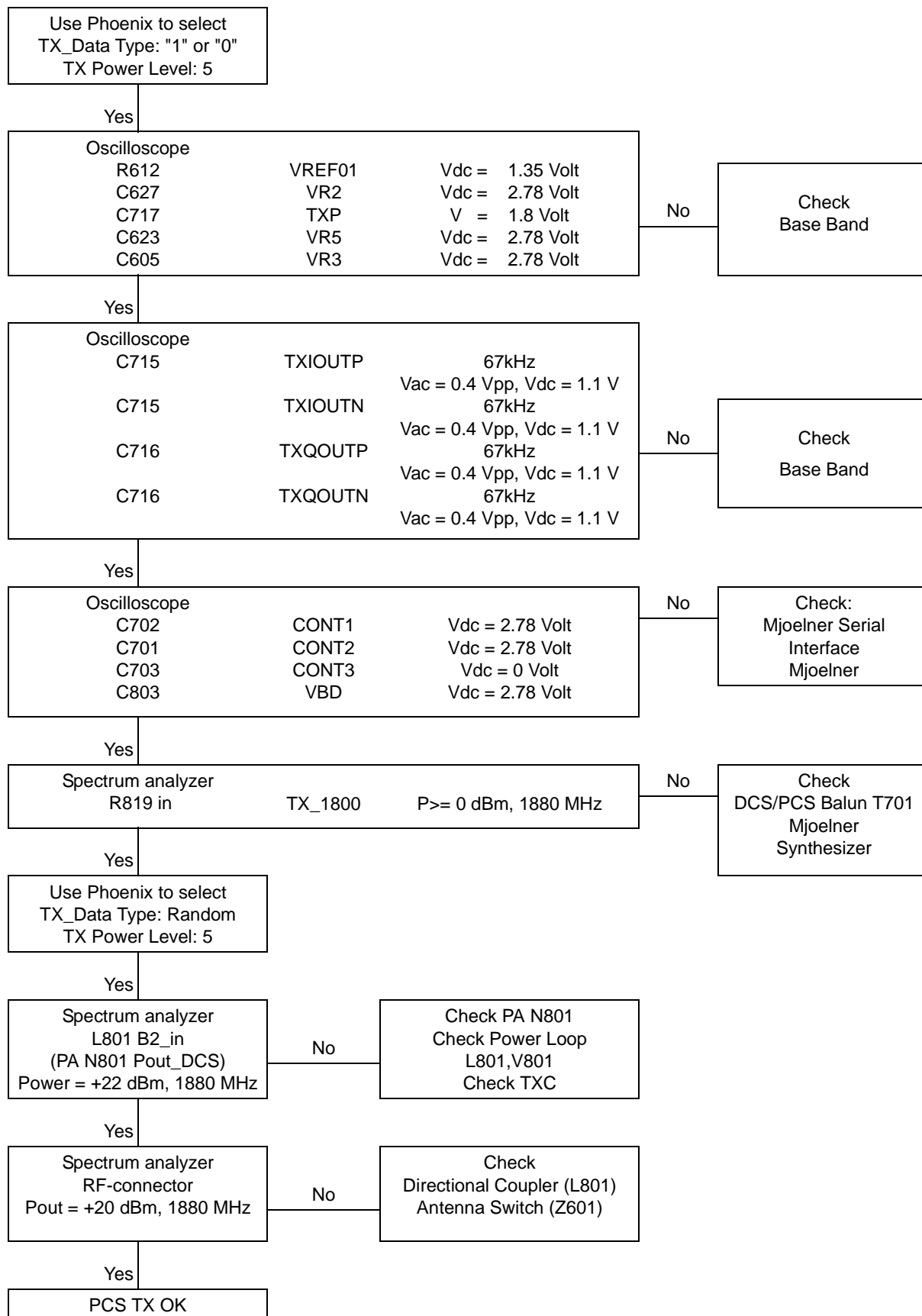

## Synthesizer Description and Trouble Shooting

One PLL synthesizer is generating all the required frequencies of the 3 bands for RX and TX. The VCO frequency is divided by 2 or by 4 in Mjoelner depending on the active band.

### General instructions for Synthesizer trouble shooting

Connect the phone to a PC with DAU-9T cable (RS232) or DKU-5 cable (USB). The PC must have Phoenix Service Software and dongle installed.

Then follow the instructions below.

### Check Synthesizer Operation

Start Phoenix Service Software and open FBUS connection.

Select	Scan Product	Ctrl-R
--------	--------------	--------

Wait until phone information is shown in the lower right corner of the screen.

Set operating mode to local mode.

Start RF Control window:

Select	Maintenance	Alt-M
	Tuning	T
	RF Controls	F

Wait until the RF Controls window has popped up.

Set the synthesizer to the following mode:

Select	Band	GSM 900
	Active unit	RX
	Operation mode	Continuous
	RX/TX Channel	37

The setup should now look like this:

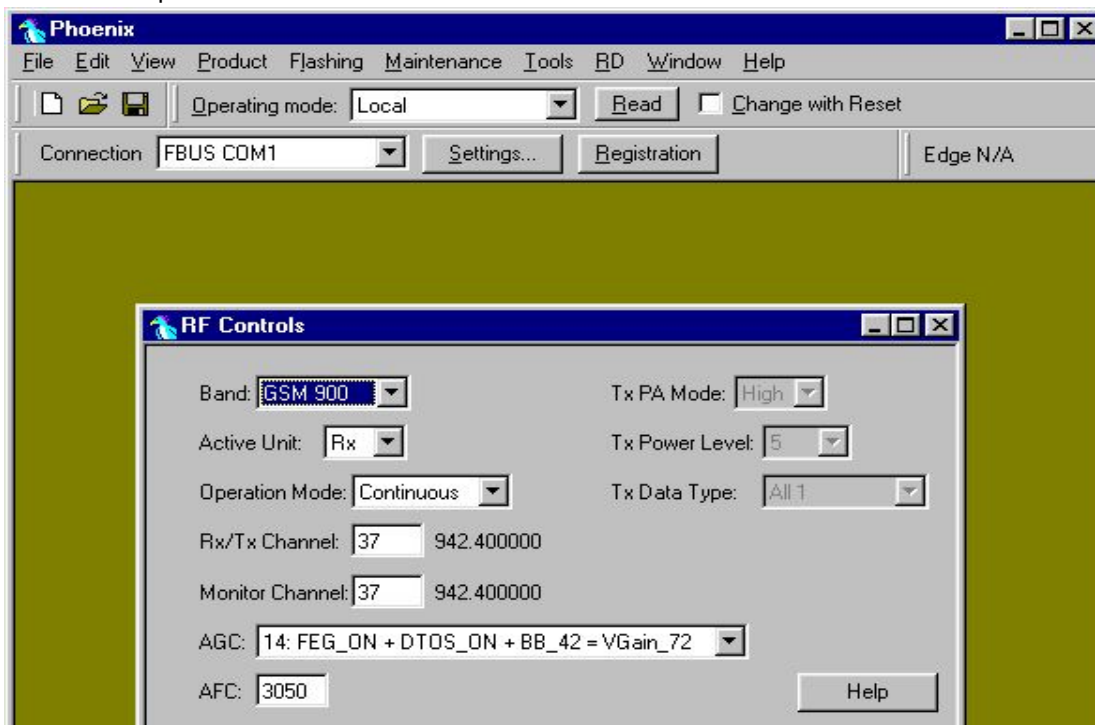

The frequency of 3769.6MHz at the output of the VCO (G701) has to be measured with a resistive probe and a spectrum analyzer.

The tuning voltage can easily be measured at the Vc input of the VCO (C712). The tuning voltage should be **2.3V<sub>DC</sub> .. 2.8V<sub>DC</sub> at f<sub>VCO</sub> = 3769.6MHz**. The (tuning sensitivity of the VCO is typically 240MHz/V).

If this is not the case, please refer to section "Fault finding chart for PLL Synthesizer" below.

## 26 MHz Reference Oscillator (VCXO)

The VCXO is integrated in the Mjoelner RF-ASIC (N601). The only external component is the 26 MHz crystal (B601).

The reference oscillator has two functions:

- Reference frequency for the PLL synthesizer.
- System clock for BB (RfClk\_I = 26 MHz).

For an error free initial synchronization, the 26MHz frequency of the VCXO must be accurate enough. Therefore, a VCXO-calibration value is written via the serial Bus into the RefOSCCAL register of Mjoelner and an additional bit in the RefOSCCntI register of the Mjoelner. That is necessary for the rough calibration of the VCXO

The VCXO is fine tuned by programming the AFC value via the serial bus of Mjoelner. The necessary AFC value is written into the RefOSCAFC register in Mjoelner.

## VCO

The VCO is able to generate frequencies in the range of 3420MHz to 3980MHz when the PLL is working properly. The frequency of the VCO signal is divided by 2 or by 4 in Mjoelner RF-ASIC. This allows the generation of all the frequencies in the EGSM900, GSM1800 and GSM1900 bands both RX and TX.

The output frequency of the VCO is controlled by a DC voltage ( $V_c$ ) of the PLL loop filter. The valid range of  $V_c$  is 0.7V– 3.8V when the PLL is in the steady state. The typical tuning sensitivity is 240MHz/V. Even if the PLL is not working properly ( $V_c$  outside the valid range) a frequency at the output of the VCO can be detected, between 3GHz and 4GHz (if the VCO itself is OK).

**Note:** that there are two different kinds of PAs applicable (from Agilent and Hitachi).

## Fault Finding Chart for PLL Synthesizer

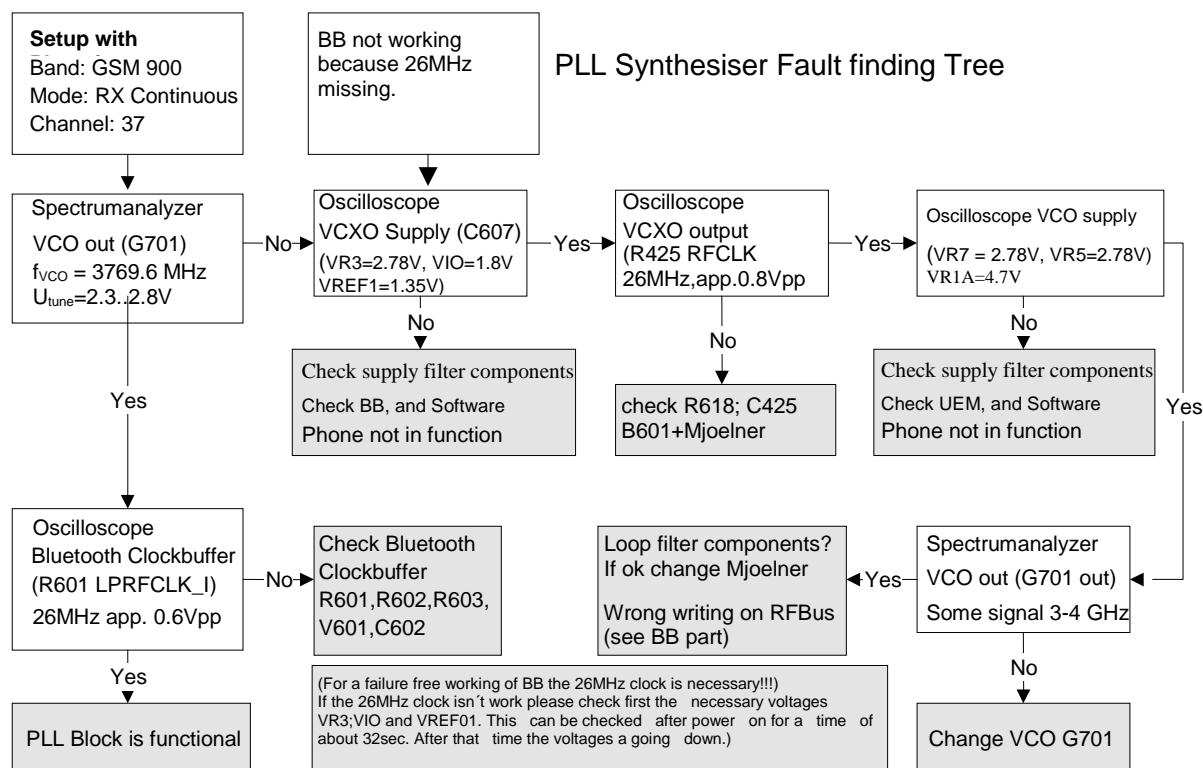

Figure 10: PLL Sythesizer Fault Finding Chart

It is important to note that the power supply of the VCXO (VR3) is only switched off in the so-called 'Deep Sleep Mode' and the power supply of the VCO (G701 VR7) is switched off in so-called 'Sleep Mode'.



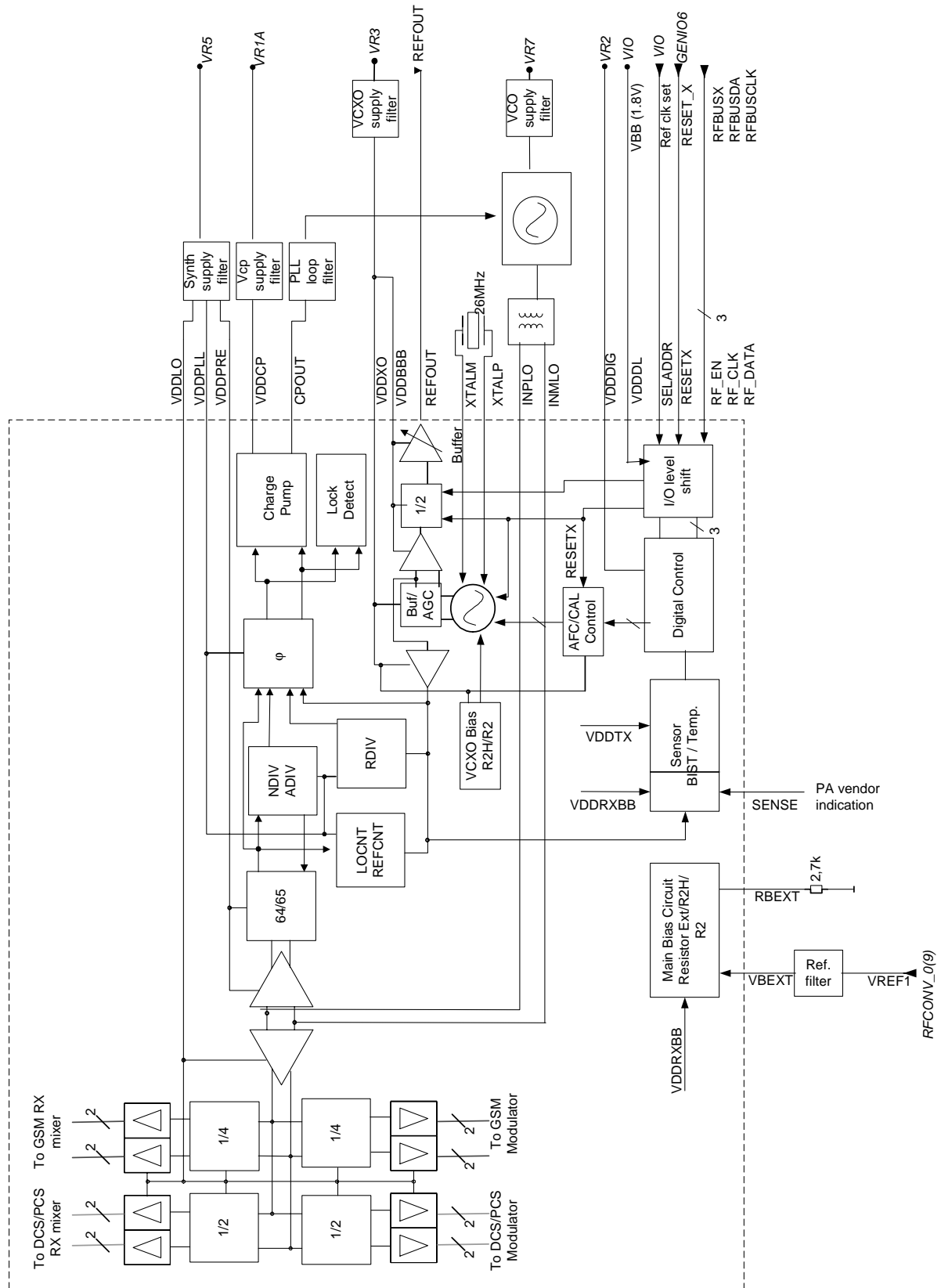

Figure 12: PLL Block Diagram

## Frequency Lists

## EGSM900

CH	TX	RX	VCO TX	VCO RX	CH	TX	RX	VCO TX	VCO RX	CH	TX	RX	VCO TX	VCO RX
975	880,2	925,2	3520,8	3700,8	1	890,2	935,2	3560,8	3740,8	63	902,6	947,6	3610,4	3790,4
976	880,4	925,4	3521,6	3701,6	2	890,4	935,4	3561,6	3741,6	64	902,8	947,8	3611,2	3791,2
977	880,6	925,6	3522,4	3702,4	3	890,6	935,6	3562,4	3742,4	65	903,0	948,0	3612,0	3792,0
978	880,8	925,8	3523,2	3703,2	4	890,8	935,8	3563,2	3743,2	66	903,2	948,2	3612,8	3792,8
979	881,0	926,0	3524,0	3704,0	5	891,0	936,0	3564,0	3744,0	67	903,4	948,4	3613,6	3793,6
980	881,2	926,2	3524,8	3704,8	6	891,2	936,2	3564,8	3744,8	68	903,6	948,6	3614,4	3794,4
981	881,4	926,4	3525,6	3705,6	7	891,4	936,4	3565,6	3745,6	69	903,8	948,8	3615,2	3795,2
982	881,6	926,6	3526,4	3706,4	8	891,6	936,6	3566,4	3746,4	70	904,0	949,0	3616,0	3796,0
983	881,8	926,8	3527,2	3707,2	9	891,8	936,8	3567,2	3747,2	71	904,2	949,2	3616,8	3796,8
984	882,0	927,0	3528,0	3708,0	10	892,0	937,0	3568,0	3748,0	72	904,4	949,4	3617,6	3797,6
985	882,2	927,2	3528,8	3708,8	11	892,2	937,2	3568,8	3748,8	73	904,6	949,6	3618,4	3798,4
986	882,4	927,4	3529,6	3709,6	12	892,4	937,4	3569,6	3749,6	74	904,8	949,8	3619,2	3799,2
987	882,6	927,6	3530,4	3710,4	13	892,6	937,6	3570,4	3750,4	75	905,0	950,0	3620,0	3800,0
988	882,8	927,8	3531,2	3711,2	14	892,8	937,8	3571,2	3751,2	76	905,2	950,2	3620,8	3800,8
989	883,0	928,0	3532,0	3712,0	15	893,0	938,0	3572,0	3752,0	77	905,4	950,4	3621,6	3801,6
990	883,2	928,2	3532,8	3712,8	16	893,2	938,2	3572,8	3752,8	78	905,6	950,6	3622,4	3802,4
991	883,4	928,4	3533,6	3713,6	17	893,4	938,4	3573,6	3753,6	79	905,8	950,8	3623,2	3803,2
992	883,6	928,6	3534,4	3714,4	18	893,6	938,6	3574,4	3754,4	80	906,0	951,0	3624,0	3804,0
993	883,8	928,8	3535,2	3715,2	19	893,8	938,8	3575,2	3755,2	81	906,2	951,2	3624,8	3804,8
994	884,0	929,0	3536,0	3716,0	20	894,0	939,0	3576,0	3756,0	82	906,4	951,4	3625,6	3805,6
995	884,2	929,2	3536,8	3716,8	21	894,2	939,2	3576,8	3756,8	83	906,6	951,6	3626,4	3806,4
996	884,4	929,4	3537,6	3717,6	22	894,4	939,4	3577,6	3757,6	84	906,8	951,8	3627,2	3807,2
997	884,6	929,6	3538,4	3718,4	23	894,6	939,6	3578,4	3758,4	85	907,0	952,0	3628,0	3808,0
998	884,8	929,8	3539,2	3719,2	24	894,8	939,8	3579,2	3759,2	86	907,2	952,2	3628,8	3808,8
999	885,0	930,0	3540,0	3720,0	25	895,0	940,0	3580,0	3760,0	87	907,4	952,4	3629,6	3809,6
1000	885,2	930,2	3540,8	3720,8	26	895,2	940,2	3580,8	3760,8	88	907,6	952,6	3630,4	3810,4
1001	885,4	930,4	3541,6	3721,6	27	895,4	940,4	3581,6	3761,6	89	907,8	952,8	3631,2	3811,2
1002	885,6	930,6	3542,4	3722,4	28	895,6	940,6	3582,4	3762,4	90	908,0	953,0	3632,0	3812,0
1003	885,8	930,8	3543,2	3723,2	29	895,8	940,8	3583,2	3763,2	91	908,2	953,2	3632,8	3812,8
1004	886,0	931,0	3544,0	3724,0	30	896,0	941,0	3584,0	3764,0	92	908,4	953,4	3633,6	3813,6
1005	886,2	931,2	3544,8	3724,8	31	896,2	941,2	3584,8	3764,8	93	908,6	953,6	3634,4	3814,4
1006	886,4	931,4	3545,6	3725,6	32	896,4	941,4	3585,6	3765,6	94	908,8	953,8	3635,2	3815,2
1007	886,6	931,6	3546,4	3726,4	33	896,6	941,6	3586,4	3766,4	95	909,0	954,0	3636,0	3816,0
1008	886,8	931,8	3547,2	3727,2	34	896,8	941,8	3587,2	3767,2	96	909,2	954,2	3636,8	3816,8
1009	887,0	932,0	3548,0	3728,0	35	897,0	942,0	3588,0	3768,0	97	909,4	954,4	3637,6	3817,6
1010	887,2	932,2	3548,8	3728,8	36	897,2	942,2	3588,8	3768,8	98	909,6	954,6	3638,4	3818,4
1011	887,4	932,4	3549,6	3729,6	37	897,4	942,4	3589,6	3769,6	99	909,8	954,8	3639,2	3819,2
1012	887,6	932,6	3550,4	3730,4	38	897,6	942,6	3590,4	3770,4	100	910,0	955,0	3640,0	3820,0
1013	887,8	932,8	3551,2	3731,2	39	897,8	942,8	3591,2	3771,2	101	910,2	955,2	3640,8	3820,8
1014	888,0	933,0	3552,0	3732,0	40	898,0	943,0	3592,0	3772,0	102	910,4	955,4	3641,6	3821,6
1015	888,2	933,2	3552,8	3732,8	41	898,2	943,2	3592,8	3772,8	103	910,6	955,6	3642,4	3822,4
1016	888,4	933,4	3553,6	3733,6	42	898,4	943,4	3593,6	3773,6	104	910,8	955,8	3643,2	3823,2
1017	888,6	933,6	3554,4	3734,4	43	898,6	943,6	3594,4	3774,4	105	911,0	956,0	3644,0	3824,0
1018	888,8	933,8	3555,2	3735,2	44	898,8	943,8	3595,2	3775,2	106	911,2	956,2	3644,8	3824,8
1019	889,0	934,0	3556,0	3736,0	45	899,0	944,0	3596,0	3776,0	107	911,4	956,4	3645,6	3825,6
1020	889,2	934,2	3556,8	3736,8	46	899,2	944,2	3596,8	3776,8	108	911,6	956,6	3646,4	3826,4
1021	889,4	934,4	3557,6	3737,6	47	899,4	944,4	3597,6	3777,6	109	911,8	956,8	3647,2	3827,2
1022	889,6	934,6	3558,4	3738,4	48	899,6	944,6	3598,4	3778,4	110	912,0	957,0	3648,0	3828,0
1023	889,8	934,8	3559,2	3739,2	49	899,8	944,8	3599,2	3779,2	111	912,2	957,2	3648,8	3828,8
0	890,0	935,0	3560,0	3740,0	50	900,0	945,0	3600,0	3780,0	112	912,4	957,4	3649,6	3829,6
					51	900,2	945,2	3600,8	3780,8	113	912,6	957,6	3650,4	3830,4
					52	900,4	945,4	3601,6	3781,6	114	912,8	957,8	3651,2	3831,2
					53	900,6	945,6	3602,4	3782,4	115	913,0	958,0	3652,0	3832,0
					54	900,8	945,8	3603,2	3783,2	116	913,2	958,2	3652,8	3832,8
					55	901,0	946,0	3604,0	3784,0	117	913,4	958,4	3653,6	3833,6
					56	901,2	946,2	3604,8	3784,8	118	913,6	958,6	3654,4	3834,4
					57	901,4	946,4	3605,6	3785,6	119	913,8	958,8	3655,2	3835,2
					58	901,6	946,6	3606,4	3786,4	120	914,0	959,0	3656,0	3836,0
					59	901,8	946,8	3607,2	3787,2	121	914,2	959,2	3656,8	3836,8
					60	902,0	947,0	3608,0	3788,0	122	914,4	959,4	3657,6	3837,6
					61	902,2	947,2	3608,8	3788,8	123	914,6	959,6	3658,4	3838,4
					62	902,4	947,4	3609,6	3789,6	124	914,8	959,8	3659,2	3839,2

GSM1800

CH	TX	RX	VCO TX	VCO RX	CH	TX	RX	VCO TX	VCO RX	CH	TX	RX	VCO TX	VCO RX	CH	TX	RX	VCO TX	VCO RX
512	1710.2	1805.2	3420.4	3610.4	606	1729.0	1824.0	3458.0	3648.0	700	1747.8	1842.8	3495.6	3685.6	794	1766.6	1861.6	3533.2	3723.2
513	1710.4	1805.4	3420.8	3610.8	607	1729.2	1824.2	3458.4	3648.4	701	1748.0	1843.0	3496.0	3686.0	795	1766.8	1861.8	3533.6	3723.6
514	1710.6	1805.6	3421.2	3611.2	608	1729.4	1824.4	3458.8	3648.8	702	1748.2	1843.2	3496.4	3686.4	796	1767.0	1862.0	3534.0	3724.0
515	1710.8	1805.8	3421.6	3611.6	609	1729.6	1824.6	3459.2	3649.2	703	1748.4	1843.4	3496.8	3686.8	797	1767.2	1862.2	3534.4	3724.4
516	1711.0	1806.0	3422.0	3612.0	610	1729.8	1824.8	3459.6	3649.6	704	1748.6	1843.6	3497.2	3687.2	798	1767.4	1862.4	3534.8	3724.8
517	1711.2	1806.2	3422.4	3612.4	611	1730.0	1825.0	3460.0	3650.0	705	1748.8	1843.8	3497.6	3687.6	799	1767.6	1862.6	3535.2	3725.2
518	1711.4	1806.4	3422.8	3612.8	612	1730.2	1825.2	3460.4	3650.4	706	1749.0	1844.0	3498.0	3688.0	800	1767.8	1862.8	3535.6	3725.6
519	1711.6	1806.6	3423.2	3613.2	613	1730.4	1825.4	3460.8	3650.8	707	1749.2	1844.2	3498.4	3688.4	801	1768.0	1863.0	3536.0	3726.0
520	1711.8	1806.8	3423.6	3613.6	614	1730.6	1825.6	3461.2	3651.2	708	1749.4	1844.4	3498.8	3688.8	802	1768.2	1863.2	3536.4	3726.4
521	1712.0	1807.0	3424.0	3614.0	615	1730.8	1825.8	3461.6	3651.6	709	1749.6	1844.6	3499.2	3689.2	803	1768.4	1863.4	3536.8	3726.8
522	1712.2	1807.2	3424.4	3614.4	616	1731.0	1826.0	3462.0	3652.0	710	1749.8	1844.8	3499.6	3689.6	804	1768.6	1863.6	3537.2	3727.2
523	1712.4	1807.4	3424.8	3614.8	617	1731.2	1826.2	3462.4	3652.4	711	1750.0	1845.0	3500.0	3690.0	805	1768.8	1863.8	3537.6	3727.6
524	1712.6	1807.6	3425.2	3615.2	618	1731.4	1826.4	3462.8	3652.8	712	1750.2	1845.2	3500.4	3690.4	806	1769.0	1864.0	3538.0	3728.0
525	1712.8	1807.8	3425.6	3615.6	619	1731.6	1826.6	3463.2	3653.2	713	1750.4	1845.4	3500.8	3690.8	807	1769.2	1864.2	3538.4	3728.4
526	1713.0	1808.0	3426.0	3616.0	620	1731.8	1826.8	3463.6	3653.6	714	1750.6	1845.6	3501.2	3691.2	808	1769.4	1864.4	3538.8	3728.8
527	1713.2	1808.2	3426.4	3616.4	621	1732.0	1827.0	3464.0	3654.0	715	1750.8	1845.8	3501.6	3691.6	809	1769.6	1864.6	3539.2	3729.2
528	1713.4	1808.4	3426.8	3616.8	622	1732.2	1827.2	3464.4	3654.4	716	1751.0	1846.0	3502.0	3692.0	810	1769.8	1864.8	3539.6	3729.6
529	1713.6	1808.6	3427.2	3617.2	623	1732.4	1827.4	3464.8	3654.8	717	1751.2	1846.2	3502.4	3692.4	811	1770.0	1865.0	3540.0	3730.0
530	1713.8	1808.8	3427.6	3617.6	624	1732.6	1827.6	3465.2	3655.2	718	1751.4	1846.4	3502.8	3692.8	812	1770.2	1865.2	3540.4	3730.4
531	1714.0	1809.0	3428.0	3618.0	625	1732.8	1827.8	3465.6	3655.6	719	1751.6	1846.6	3503.2	3693.2	813	1770.4	1865.4	3540.8	3730.8
532	1714.2	1809.2	3428.4	3618.4	626	1733.0	1828.0	3466.0	3656.0	720	1751.8	1846.8	3503.6	3693.6	814	1770.6	1865.6	3541.2	3731.2
533	1714.4	1809.4	3428.8	3618.8	627	1733.2	1828.2	3466.4	3656.4	721	1752.0	1847.0	3504.0	3694.0	815	1770.8	1865.8	3541.6	3731.6
534	1714.6	1809.6	3429.2	3619.2	628	1733.4	1828.4	3466.8	3656.8	722	1752.2	1847.2	3504.4	3694.4	816	1771.0	1866.0	3542.0	3732.0
535	1714.8	1809.8	3429.6	3619.6	629	1733.6	1828.6	3467.2	3657.2	723	1752.4	1847.4	3504.8	3694.8	817	1771.2	1866.2	3542.4	3732.4
536	1715.0	1810.0	3430.0	3620.0	630	1733.8	1828.8	3467.6	3657.6	724	1752.6	1847.6	3505.2	3695.2	818	1771.4	1866.4	3542.8	3732.8
537	1715.2	1810.2	3430.4	3620.4	631	1734.0	1829.0	3468.0	3658.0	725	1752.8	1847.8	3505.6	3695.6	819	1771.6	1866.6	3543.2	3733.2
538	1715.4	1810.4	3430.8	3620.8	632	1734.2	1829.2	3468.4	3658.4	726	1753.0	1848.0	3506.0	3696.0	820	1771.8	1866.8	3543.6	3733.6
539	1715.6	1810.6	3431.2	3621.2	633	1734.4	1829.4	3468.8	3658.8	727	1753.2	1848.2	3506.4	3696.4	821	1772.0	1867.0	3544.0	3734.0
540	1715.8	1810.8	3431.6	3621.6	634	1734.6	1829.6	3469.2	3659.2	728	1753.4	1848.4	3506.8	3696.8	822	1772.2	1867.2	3544.4	3734.4
541	1716.0	1811.0	3432.0	3622.0	635	1734.8	1829.8	3469.6	3659.6	729	1753.6	1848.6	3507.2	3697.2	823	1772.4	1867.4	3544.8	3734.8
542	1716.2	1811.2	3432.4	3622.4	636	1735.0	1830.0	3470.0	3660.0	730	1753.8	1848.8	3507.6	3697.6	824	1772.6	1867.6	3545.2	3735.2
543	1716.4	1811.4	3432.8	3622.8	637	1735.2	1830.2	3470.4	3660.4	731	1754.0	1849.0	3508.0	3698.0	825	1772.8	1867.8	3545.6	3735.6
544	1716.6	1811.6	3433.2	3623.2	638	1735.4	1830.4	3470.8	3660.8	732	1754.2	1849.2	3508.4	3698.4	826	1773.0	1868.0	3546.0	3736.0
545	1716.8	1811.8	3433.6	3623.6	639	1735.6	1830.6	3471.2	3661.2	733	1754.4	1849.4	3508.8	3698.8	827	1773.2	1868.2	3546.4	3736.4
546	1717.0	1812.0	3434.0	3624.0	640	1735.8	1830.8	3471.6	3661.6	734	1754.6	1849.6	3509.2	3699.2	828	1773.4	1868.4	3546.8	3736.8
547	1717.2	1812.2	3434.4	3624.4	641	1736.0	1831.0	3472.0	3662.0	735	1754.8	1849.8	3509.6	3699.6	829	1773.6	1868.6	3547.2	3737.2
548	1717.4	1812.4	3434.8	3624.8	642	1736.2	1831.2	3472.4	3662.4	736	1755.0	1850.0	3510.0	3700.0	830	1773.8	1868.8	3547.6	3737.6
549	1717.6	1812.6	3435.2	3625.2	643	1736.4	1831.4	3472.8	3662.8	737	1755.2	1850.2	3510.4	3700.4	831	1774.0	1869.0	3548.0	3738.0
550	1717.8	1812.8	3435.6	3625.6	644	1736.6	1831.6	3473.2	3663.2	738	1755.4	1850.4	3510.8	3700.8	832	1774.2	1869.2	3548.4	3738.4
551	1718.0	1813.0	3436.0	3626.0	645	1736.8	1831.8	3473.6	3663.6	739	1755.6	1850.6	3511.2	3701.2	833	1774.4	1869.4	3548.8	3738.8
552	1718.2	1813.2	3436.4	3626.4	646	1737.0	1832.0	3474.0	3664.0	740	1755.8	1850.8	3511.6	3701.6	834	1774.6	1869.6	3549.2	3739.2
553	1718.4	1813.4	3436.8	3626.8	647	1737.2	1832.2	3474.4	3664.4	741	1756.0	1851.0	3512.0	3702.0	835	1774.8	1869.8	3549.6	3739.6
554	1718.6	1813.6	3437.2	3627.2	648	1737.4	1832.4	3474.8	3664.8	742	1756.2	1851.2	3512.4	3702.4	836	1775.0	1870.0	3550.0	3740.0
555	1718.8	1813.8	3437.6	3627.6	649	1737.6	1832.6	3475.2	3665.2	743	1756.4	1851.4	3512.8	3702.8	837	1775.2	1870.2	3550.4	3740.4
556	1719.0	1814.0	3438.0	3628.0	650	1737.8	1832.8	3475.6	3665.6	744	1756.6	1851.6	3513.2	3703.2	838	1775.4	1870.4	3550.8	3740.8
557	1719.2	1814.2	3438.4	3628.4	651	1738.0	1833.0	3476.0	3666.0	745	1756.8	1851.8	3513.6	3703.6	839	1775.6	1870.6	3551.2	3741.2
558	1719.4	1814.4	3438.8	3628.8	652	1738.2	1833.2	3476.4	3666.4	746	1757.0	1852.0	3514.0	3704.0	840	1775.8	1870.8	3551.6	3741.6
559	1719.6	1814.6	3439.2	3629.2	653	1738.4	1833.4	3476.8	3666.8	747	1757.2	1852.2	3514.4	3704.4	841	1776.0	1871.0	3552.0	3742.0
560	1719.8	1814.8	3439.6	3629.6	654	1738.6	1833.6	3477.2	3667.2	748	1757.4	1852.4	3514.8	3704.8	842	1776.2	1871.2	3552.4	3742.4
561	1720.0	1815.0	3440.0	3630.0	655	1738.8	1833.8	3477.6	3667.6	749	1757.6	1852.6	3515.2	3705.2	843	1776.4	1871.4	3552.8	3742.8
562	1720.2	1815.2	3440.4	3630.4	656	1739.0	1834.0	3478.0	3668.0	750	1757.8	1852.8	3515.6	3705.6	844	1776.6	1871.6	3553.2	3743.2
563	1720.4	1815.4	3440.8	3630.8	657	1739.2	1834.2	3478.4	3668.4	751	1758.0	1853.0	3516.0	3706.0	845	1776.8	1871.8	3553.6	3743.6
564	1720.6	1815.6	3441.2	3631.2	658	1739.4	1834.4	3478.8	3668.8	752	1758.2	1853.2	3516.4	3706.4	846	1777.0	1872.0	3554.0	3744.0
565	1720.8	1815.8	3441.6	3631.6	659	1739.6	1834.6	3479.2	3669.2	753	1758.4	1853.4	3516.8	3706.8	847	1777.2	1872.2	3554.4	3744.4
566	1721.0	1816.0	3442.0	3632.0	660	1739.8	1834.8	3479.6	3669.6	754	1758.6	1853.6	3517.2	3707.2	848	1777.4	1872.4	3554.8	3744.8
567	1721.2	1816.2	3442.4	3632.4	661	1740.0	1835.0	3480.0	3670.0	755	1758.8	1853.8	3517.6	3707.6	849	1777.6	1872.6	3555.2	3745.2
568	1721.4	18																	

GSM1900

CH	TX	RX	VCO TX	VCO RX	CH	TX	RX	VCO TX	VCO RX	CH	TX	RX	VCO TX	VCO RX	CH	TX	RX	VCO TX	VCO RX
512	1850.2	1930.2	3700.4	3860.4	606	1869.0	1949.0	3738.0	3898.0	700	1887.8	1967.8	3775.6	3935.6	794	1906.6	1986.6	3813.2	3973.2
513	1850.4	1930.4	3700.8	3860.8	607	1869.2	1949.2	3738.4	3898.4	701	1888.0	1968.0	3776.0	3936.0	795	1906.8	1986.8	3813.6	3973.6
514	1850.6	1930.6	3701.2	3861.2	608	1869.4	1949.4	3738.8	3898.8	702	1888.2	1968.2	3776.4	3936.4	796	1907.0	1987.0	3814.0	3974.0
515	1850.8	1930.8	3701.6	3861.6	609	1869.6	1949.6	3739.2	3899.2	703	1888.4	1968.4	3776.8	3936.8	797	1907.2	1987.2	3814.4	3974.4
516	1851.0	1931.0	3702.0	3862.0	610	1869.8	1949.8	3739.6	3899.6	704	1888.6	1968.6	3777.2	3937.2	798	1907.4	1987.4	3814.8	3974.8
517	1851.2	1931.2	3702.4	3862.4	611	1870.0	1950.0	3740.0	3900.0	705	1888.8	1968.8	3777.6	3937.6	799	1907.6	1987.6	3815.2	3975.2
518	1851.4	1931.4	3702.8	3862.8	612	1870.2	1950.2	3740.4	3900.4	706	1889.0	1969.0	3778.0	3938.0	800	1907.8	1987.8	3815.6	3975.6
519	1851.6	1931.6	3703.2	3863.2	613	1870.4	1950.4	3740.8	3900.8	707	1889.2	1969.2	3778.4	3938.4	801	1908.0	1988.0	3816.0	3976.0
520	1851.8	1931.8	3703.6	3863.6	614	1870.6	1950.6	3741.2	3901.2	708	1889.4	1969.4	3778.8	3938.8	802	1908.2	1988.2	3816.4	3976.4
521	1852.0	1932.0	3704.0	3864.0	615	1870.8	1950.8	3741.6	3901.6	709	1889.6	1969.6	3779.2	3939.2	803	1908.4	1988.4	3816.8	3976.8
522	1852.2	1932.2	3704.4	3864.4	616	1871.0	1951.0	3742.0	3902.0	710	1889.8	1969.8	3779.6	3939.6	804	1908.6	1988.6	3817.2	3977.2
523	1852.4	1932.4	3704.8	3864.8	617	1871.2	1951.2	3742.4	3902.4	711	1890.0	1970.0	3780.0	3940.0	805	1908.8	1988.8	3817.6	3977.6
524	1852.6	1932.6	3705.2	3865.2	618	1871.4	1951.4	3742.8	3902.8	712	1890.2	1970.2	3780.4	3940.4	806	1909.0	1989.0	3818.0	3978.0
525	1852.8	1932.8	3705.6	3865.6	619	1871.6	1951.6	3743.2	3903.2	713	1890.4	1970.4	3780.8	3940.8	807	1909.2	1989.2	3818.4	3978.4
526	1853.0	1933.0	3706.0	3866.0	620	1871.8	1951.8	3743.6	3903.6	714	1890.6	1970.6	3781.2	3941.2	808	1909.4	1989.4	3818.8	3978.8
527	1853.2	1933.2	3706.4	3866.4	621	1872.0	1952.0	3744.0	3904.0	715	1890.8	1970.8	3781.6	3941.6	809	1909.6	1989.6	3819.2	3979.2
528	1853.4	1933.4	3706.8	3866.8	622	1872.2	1952.2	3744.4	3904.4	716	1891.0	1971.0	3782.0	3942.0	810	1909.8	1989.8	3819.6	3979.6
529	1853.6	1933.6	3707.2	3867.2	623	1872.4	1952.4	3744.8	3904.8	717	1891.2	1971.2	3782.4	3942.4					
530	1853.8	1933.8	3707.6	3867.6	624	1872.6	1952.6	3745.2	3905.2	718	1891.4	1971.4	3782.8	3942.8					
531	1854.0	1934.0	3708.0	3868.0	625	1872.8	1952.8	3745.6	3905.6	719	1891.6	1971.6	3783.2	3943.2					
532	1854.2	1934.2	3708.4	3868.4	626	1873.0	1953.0	3746.0	3906.0	720	1891.8	1971.8	3783.6	3943.6					
533	1854.4	1934.4	3708.8	3868.8	627	1873.2	1953.2	3746.4	3906.4	721	1892.0	1972.0	3784.0	3944.0					
534	1854.6	1934.6	3709.2	3869.2	628	1873.4	1953.4	3746.8	3906.8	722	1892.2	1972.2	3784.4	3944.4					
535	1854.8	1934.8	3709.6	3869.6	629	1873.6	1953.6	3747.2	3907.2	723	1892.4	1972.4	3784.8	3944.8					
536	1855.0	1935.0	3710.0	3870.0	630	1873.8	1953.8	3747.6	3907.6	724	1892.6	1972.6	3785.2	3945.2					
537	1855.2	1935.2	3710.4	3870.4	631	1874.0	1954.0	3748.0	3908.0	725	1892.8	1972.8	3785.6	3945.6					
538	1855.4	1935.4	3710.8	3870.8	632	1874.2	1954.2	3748.4	3908.4	726	1893.0	1973.0	3786.0	3946.0					
539	1855.6	1935.6	3711.2	3871.2	633	1874.4	1954.4	3748.8	3908.8	727	1893.2	1973.2	3786.4	3946.4					
540	1855.8	1935.8	3711.6	3871.6	634	1874.6	1954.6	3749.2	3909.2	728	1893.4	1973.4	3786.8	3946.8					
541	1856.0	1936.0	3712.0	3872.0	635	1874.8	1954.8	3749.6	3909.6	729	1893.6	1973.6	3787.2	3947.2					
542	1856.2	1936.2	3712.4	3872.4	636	1875.0	1955.0	3750.0	3910.0	730	1893.8	1973.8	3787.6	3947.6					
543	1856.4	1936.4	3712.8	3872.8	637	1875.2	1955.2	3750.4	3910.4	731	1894.0	1974.0	3788.0	3948.0					
544	1856.6	1936.6	3713.2	3873.2	638	1875.4	1955.4	3750.8	3910.8	732	1894.2	1974.2	3788.4	3948.4					
545	1856.8	1936.8	3713.6	3873.6	639	1875.6	1955.6	3751.2	3911.2	733	1894.4	1974.4	3788.8	3948.8					
546	1857.0	1937.0	3714.0	3874.0	640	1875.8	1955.8	3751.6	3911.6	734	1894.6	1974.6	3789.2	3949.2					
547	1857.2	1937.2	3714.4	3874.4	641	1876.0	1956.0	3752.0	3912.0	735	1894.8	1974.8	3789.6	3949.6					
548	1857.4	1937.4	3714.8	3874.8	642	1876.2	1956.2	3752.4	3912.4	736	1895.0	1975.0	3790.0	3950.0					
549	1857.6	1937.6	3715.2	3875.2	643	1876.4	1956.4	3752.8	3912.8	737	1895.2	1975.2	3790.4	3950.4					
550	1857.8	1937.8	3715.6	3875.6	644	1876.6	1956.6	3753.2	3913.2	738	1895.4	1975.4	3790.8	3950.8					
551	1858.0	1938.0	3716.0	3876.0	645	1876.8	1956.8	3753.6	3913.6	739	1895.6	1975.6	3791.2	3951.2					
552	1858.2	1938.2	3716.4	3876.4	646	1877.0	1957.0	3754.0	3914.0	740	1895.8	1975.8	3791.6	3951.6					
553	1858.4	1938.4	3716.8	3876.8	647	1877.2	1957.2	3754.4	3914.4	741	1896.0	1976.0	3792.0	3952.0					
554	1858.6	1938.6	3717.2	3877.2	648	1877.4	1957.4	3754.8	3914.8	742	1896.2	1976.2	3792.4	3952.4					
555	1858.8	1938.8	3717.6	3877.6	649	1877.6	1957.6	3755.2	3915.2	743	1896.4	1976.4	3792.8	3952.8					
556	1859.0	1939.0	3718.0	3878.0	650	1877.8	1957.8	3755.6	3915.6	744	1896.6	1976.6	3793.2	3953.2					
557	1859.2	1939.2	3718.4	3878.4	651	1878.0	1958.0	3756.0	3916.0	745	1896.8	1976.8	3793.6	3953.6					
558	1859.4	1939.4	3718.8	3878.8	652	1878.2	1958.2	3756.4	3916.4	746	1897.0	1977.0	3794.0	3954.0					
559	1859.6	1939.6	3719.2	3879.2	653	1878.4	1958.4	3756.8	3916.8	747	1897.2	1977.2	3794.4	3954.4					
560	1859.8	1939.8	3719.6	3879.6	654	1878.6	1958.6	3757.2	3917.2	748	1897.4	1977.4	3794.8	3954.8					
561	1860.0	1940.0	3720.0	3880.0	655	1878.8	1958.8	3757.6	3917.6	749	1897.6	1977.6	3795.2	3955.2					
562	1860.2	1940.2	3720.4	3880.4	656	1879.0	1959.0	3758.0	3918.0	750	1897.8	1977.8	3795.6	3955.6					
563	1860.4	1940.4	3720.8	3880.8	657	1879.2	1959.2	3758.4	3918.4	751	1898.0	1978.0	3796.0	3956.0					
564	1860.6	1940.6	3721.2	3881.2	658	1879.4	1959.4	3758.8	3918.8	752	1898.2	1978.2	3796.4	3956.4					
565	1860.8	1940.8	3721.6	3881.6	659	1879.6	1959.6	3759.2	3919.2	753	1898.4	1978.4	3796.8	3956.8					
566	1861.0	1941.0	3722.0	3882.0	660	1879.8	1959.8	3759.6	3919.6	754	1898.6	1978.6	3797.2	3957.2					
567	1861.2	1941.2	3722.4	3882.4	661	1880.0	1960.0	3760.0	3920.0	755	1898.8	1978.8	3797.6	3957.6					
568	1861.4	1941.4	3722.8	3882.8	662	1880.2	1960.2	3760.4	3920.4	756	1899.0	1979.0	3798.0	3958.0					
569	1861.6	1941.6	3723.2	3883.2	663	1880.4	1960.4	3760.8	3920.8	757	1899.2	1979.2	3798.4	3958.4					
570	1861.8	1941.8	3723.6	3883.6	664	1880.6	1960.6	3761.2	3921.2	758	1899.4	1979.4	3798.8	3958.8					
571	1862.0	1942.0	3724.0	3884.0	665	1880.8	1960.8	3761.6	3921.6	759	1899.6	1979.6	3799.2	3959.2					
572	1862.2	1942.2	3724.4	3884.4	666	1881.0	1961.0	3762.0	3922.0	760	1899.8	1979.8	3799.6	3959.6					
573	1862.4	1942.4	3724.8	3884.8	667	1881.2	1961.2	3762.4	3922.4	761	1900.0	1980.0	3800.0	3960.0					
574	1862.6	1942.6	3725.2	3885.2	668	1881.4	1961.4	3762.8	3922.8	762	1900.2	1980.2	3800.4	3960.4					
57																			

### DC Supply Current Check

For a quick check of the DC power supplies to the diagram below. Voltage drops are measured at the respective resistors pads.

Note: that not all currents can be checked in such a way, see <na> (not applicable) in the diagram.

Voltage drop  
& current

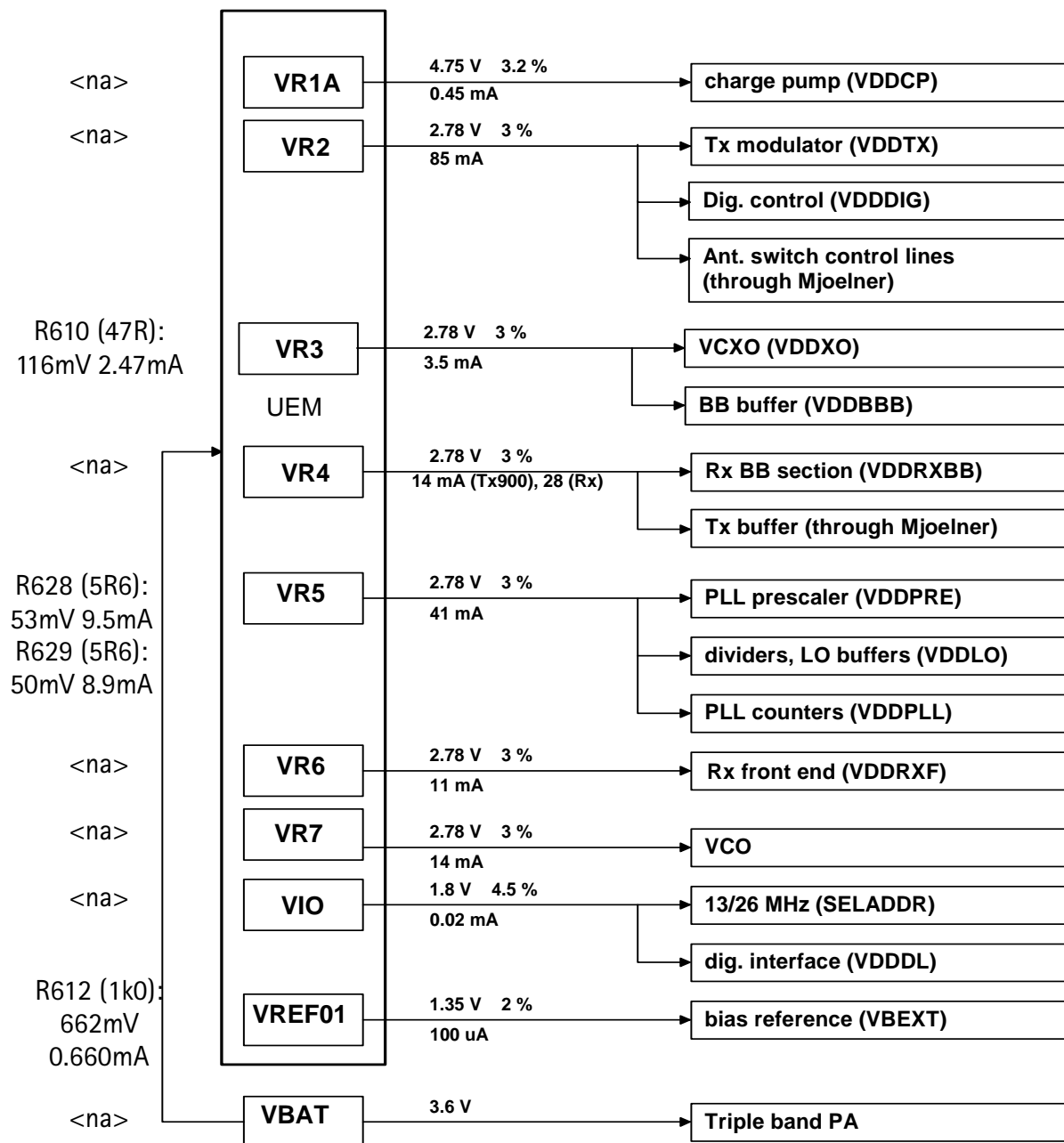

## RF Tuning Instructions

### General instructions for RF Tuning

- Provide the phone with power supply (nominal voltage is 3.7V).
- Connect the phone to a PC with DAU-9T cable (RS232) or DKU-5 cable (USB).
- Start Phoenix Service Software (dongle required).
- Open FBUS connection.
- Select:           File                            Alt-F  
                  Scan Product                    P  
Shortcut: Ctrl-R

Wait until phone information is shown in the lower right corner of the screen.

### RF Tuning after Repairs

The following tunings have to be performed after repairs:

- Repairs in the TX part will require "TX Power Level Tuning". When components around the modulator area are replaced (RF path from UEM via Mjoelner to RF PA) have been done, "TX IQ Tuning" is additionally required.
- In general repairs in the RX front-end or the PLL unit always require "RX Calibration" and "RX Band Filter Calibration".
- If Mjoelner was changed all calibrations mentioned above have to be done.

### RX Calibration

The **RX Calibration** has to be performed to determine the gains at different gain settings of the front-end and Mjoelner. The calibration must be done in all three bands.

RX Calibration requires an external signal generator. Most of the radio communication testers like CMD55 or CMU200 can be used also as a signal generator, generating a continuous RF signal with defined levels and frequencies.

**RX Calibration in EGSM900 combines two alignments: VCXO calibration and AGC calibration.** Calibration of GSM1800 and GSM1900 band only determines the AGC values.

The **VCXO calibration** detects a calibration value for VCXO control, an AFC initial value and 3 AFC-slope coefficients. The VCXO calibration ensures the function of an initial synchronization (before location update is done) when the phone has been set in Normal Mode. For an error free initial synchronization, the 26MHz frequency of the VCXO must be accurate enough. Therefore, a **VCXO cal** value is written into the RefOSCCAL register of the Mjoelner.

During VCXO-calibration, the **VCXO cal** value is changed by a DSP-algorithm until a synchronization is possible. This means that the VCXO oscillates at 26 MHz with a sufficient minimum frequency error.

To further minimize the frequency error, an initial **AFC value** is determined by the DSP and written into RefOSCAFC register of the Mjoelner.

Additionally the DSP algorithm determines three AFC slope coefficients **Slope C1, C2, C3** during VCXO calibration. One AFC slope value is not sufficient for Mjoelner, because the AFC slope is a non-linear function versus time.

The **AGC-calibration** detects the gain values of the RX chain. The AGC is looped by the RF LNA, which can be switched either on or off (gain difference between on and off state is nominally 30dB) and the BB gain which is controlled by 15 gain steps RSSI0 to RSSI14 each having a graduation of 6dB. The LNA is off at steps RSSI0 to RSSI4.

AGC-calibration detects the gain at the two gain steps RSSI4 and RSSI7. All other steps are calculated.

A value **RF\_TEMP**, which represents the RF hardware temperature, is determined during RX Calibration. This temperature value is used by DSP for RSSI reporting correction in Normal Mode of the phone. It is not displayed while calibrating.

The RX calibration is only valid if the results are within certain limits. For the most recent limits refer to the production limits of FLALI and FINUI testers.

If the results are not within these limits, the RX chain is faulty.

**RX Calibration EGSM900**

Set operating mode to local mode.

Select	Maintenance	Alt-M
	Tuning	T
	RX Calibration	C

Wait until the RX Calibration window has popped up.

Select	Band	GSM 900
	Autom.	-60 dBm
	1st Man.	-50 dBm
	2nd Man.	-85 dBm

The setup should now look like this:

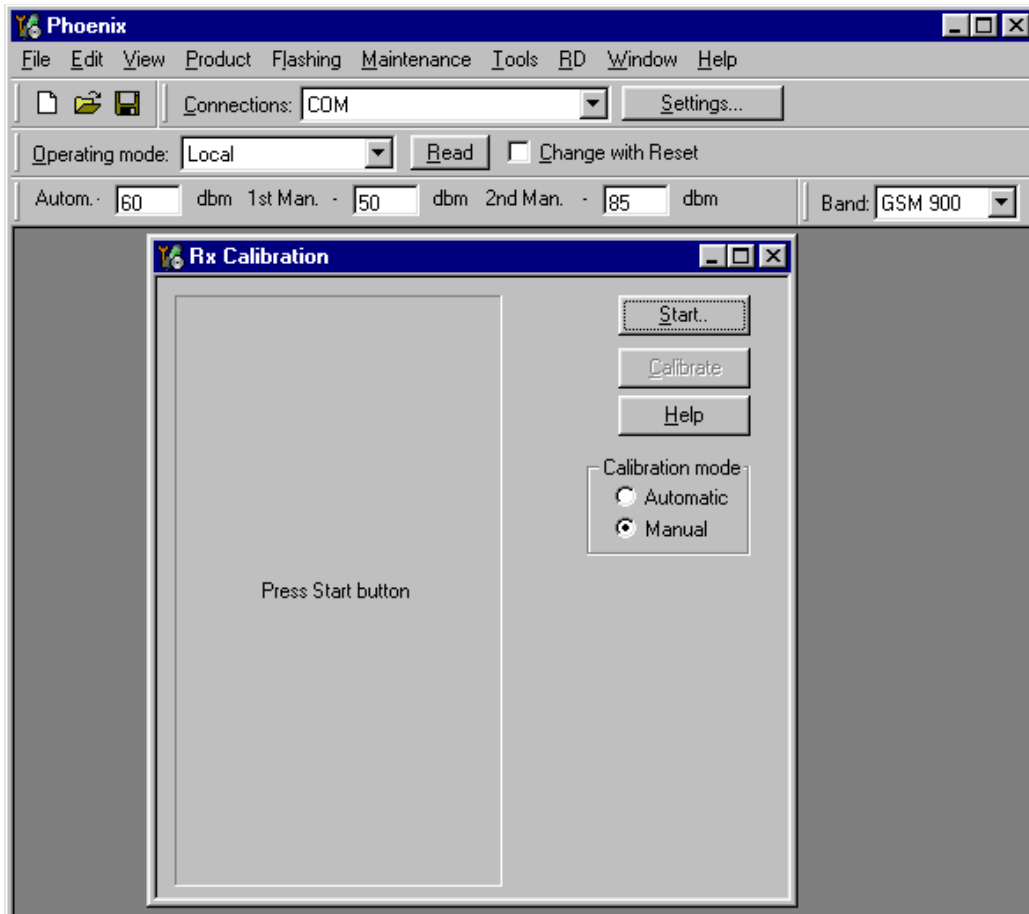

Select Automatic, press Start and a new window pops up:

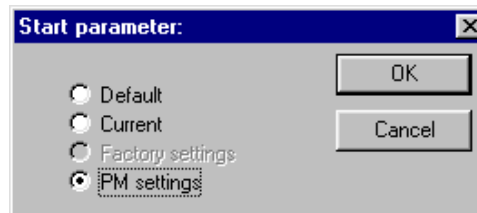

Select PM settings, press OK and the window closes.

Now it is possible to press the **Calibrate** button in the RX Calibration window.

Press Calibrate and a window pops up:

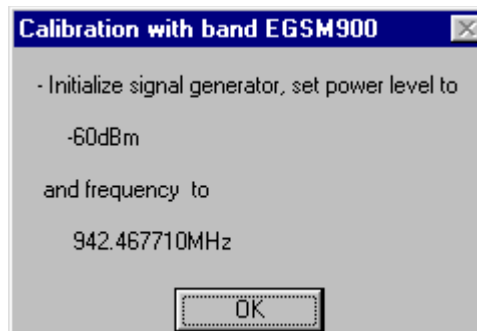



Connect an external signal generator to the RF connector of the phone and compensate for external RF cable losses. Set the generator as shown in window above. If a radio communication tester (CMD55, CMU200, 8960, MT8801) is used, assure that continuous mode is switched on and modulation switched off.

Press OK and the window closes.

A typical result will look like this:

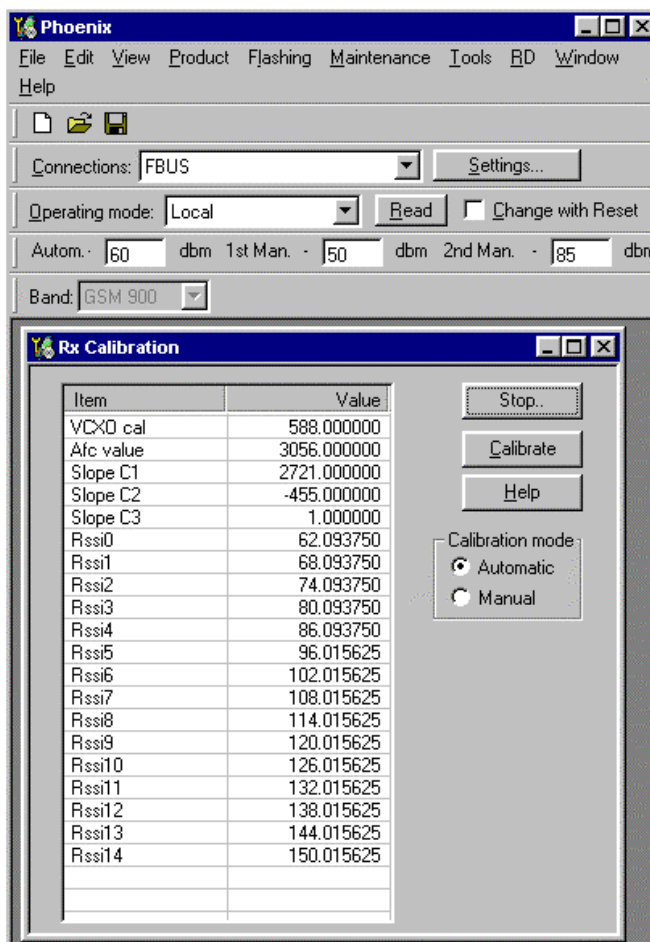

The results must be compared with the following limits:

Value	Typical	Limit min.	Limit max.
VCXO cal	568	128	767
AFC value	3162	3062	3262
Slope C1	2760	1500	3500
Slope C2	-480	-700	-300
Slope C3	1	0	1
Rssi 3	79	77	82
Rssi 6	102	100	105

For production testing a more sophisticated check of the C1 and C2 values is performed according to the following formulas:

- 1  $1312 < C2 * 0.311 + C1 * 0.395 + \text{Afc value} < 4383$
- 2  $1312 < C2 * 0.407 - C1 * 0.451 + \text{Afc value} < 4383$
- 3  $1 / [-C2 * 3.60e-5 + C1 * 1.99e-5] < 83$
- 4  $1 / [C2 * 3.15e-5 + C1 * 1.99e-5] < 83$

If C1 or C2 are outside the limits in the table above, but inside the limits calculated with the four formulas, the calibration was successful anyhow.

If Rssi 2 and Rssi 6 are within the limits, all other Rssi values are valid, too.

GSM900 receiver part has to be checked

If the whole calibration fails, the GSM900 receiver chain or the synthesizer part (including VCXO) might be defective.

If one of the values VCXO cal, AFC value, C1, C2 or C3 fails and Rssi 4 and Rssi 7 are within the limits, the crystal B601 or the RF ASIC N601 might be defective.

Press Stop in the RX Calibration window and a new window pops up:

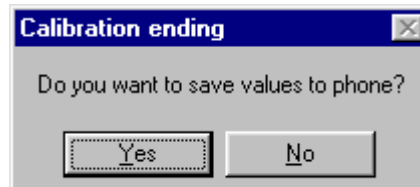

Press Yes and the EGSM RX Calibration is finished.

### RX Calibration GSM1800 (DCS/PCN)

Set operating mode to local mode.

Select	Maintenance	Alt-M
	Tuning	T
	RX Calibration	C

Wait until the RX Calibration window pops up.

Select	Band	GSM 1800
	Autom.	-60dBm
	1 <sup>st</sup> Man.	-50dBm
	2 <sup>nd</sup> Man.	-85dBm

The setup should now look like this:

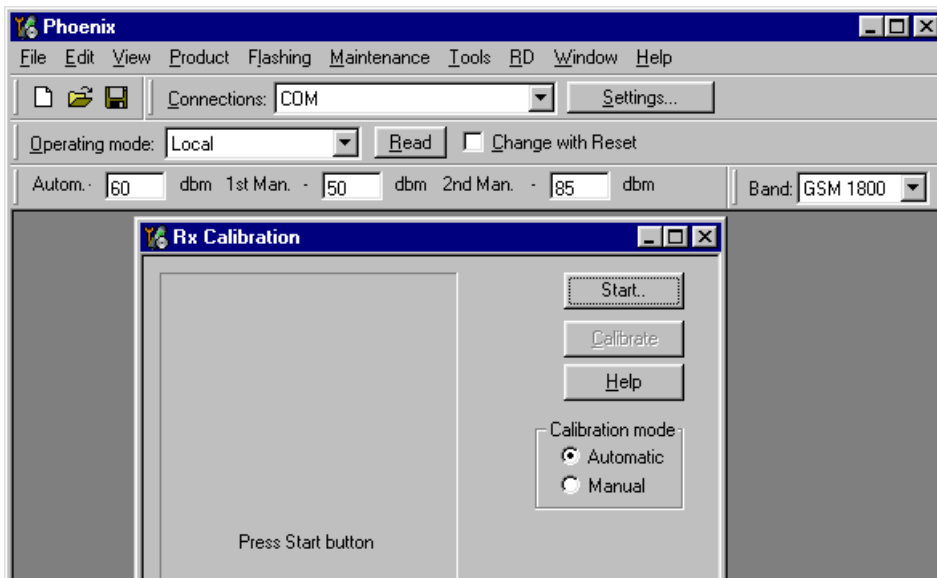

Select Automatic, press Start and a new window pops up:

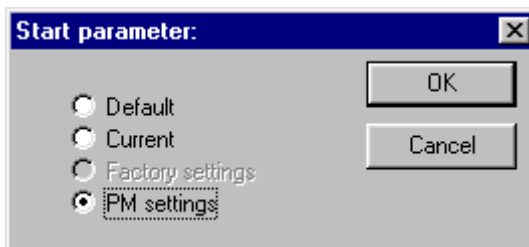

Select PM settings, press OK and the window closes.

Now it is possible to press the calibrate button in the RX Calibration window.

Press Calibrate and a window pops up:



Connect an external signal generator to the RF connector of the phone and compensate for the external RF cable losses. Set the generator as shown in the window, above. If a radio communication tester (CMD55, CMU200, 8960, MT8801) is used, assure to have continuous mode switched on and modulation switched off.

Press OK and the window closes.

A typical result will look like this:

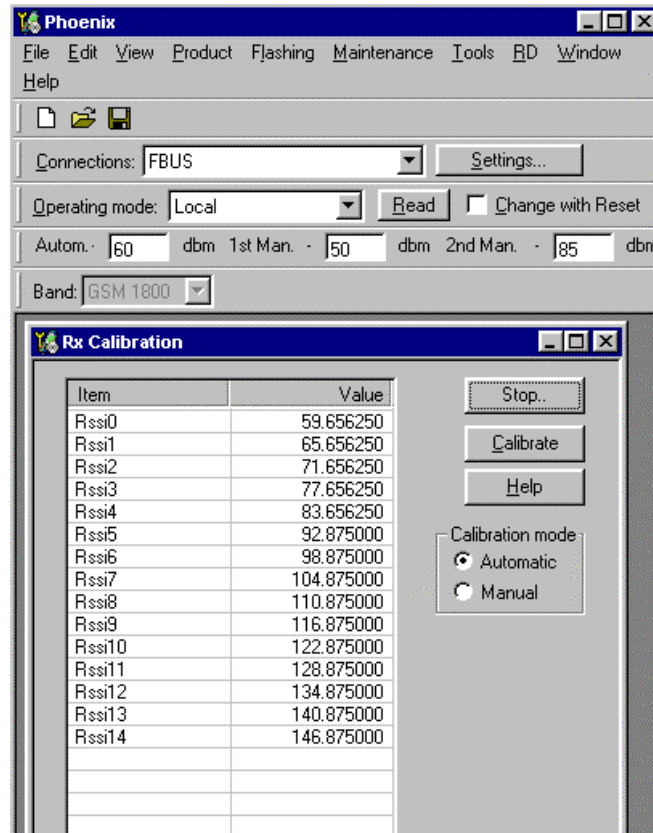

The results must be compared with the following limits:

Value	Typical	Limit min.	Limit max.
Rssi 3	76	74	79
Rssi 6	99	96	103

If Rssi 3 and Rssi 6 are within the limits, all other Rssi values are valid, too. If not, continue according to the instructions of RX fault finding flow chart.

Press Stop in the RX Calibration window and a new window pops up:

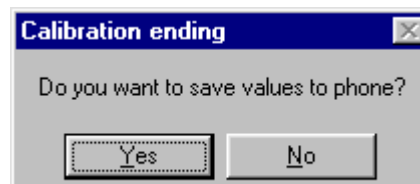

Press Yes and the GSM1800 RX Calibration is finished.

### RX Calibration GSM1900 (PCS)

Set operating mode to local mode.

Select

Maintenance  
Tuning

Alt-M  
T

RX Calibration C

Wait until the RX Calibration window pops up.

Select	Band	GSM 1900
	Autom.	-60dBm
	1 <sup>st</sup> Man.	-50dBm
	2 <sup>nd</sup> Man.	-85dBm

The setup should now look like this:

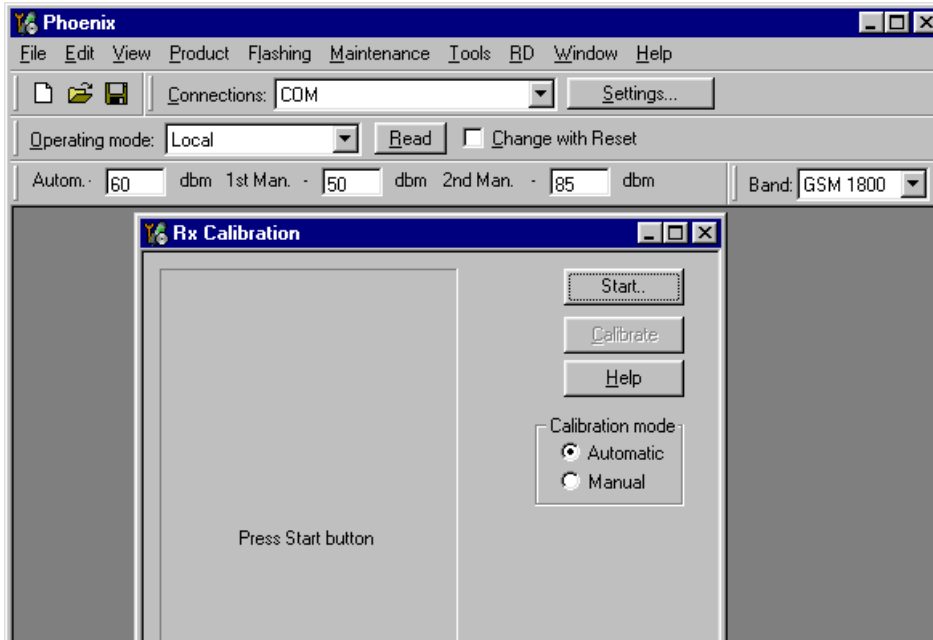

Select Automatic, press Start and a new window pops up:

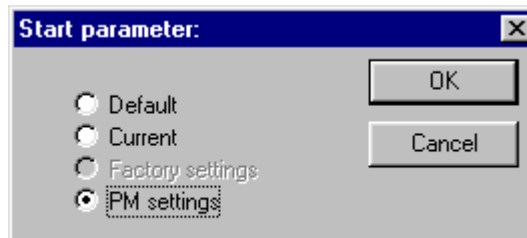

Select PM settings, press OK and the window closes.

Now it is possible to press the calibrate button in the RX Calibration window.

Press Calibrate and a window pops up:

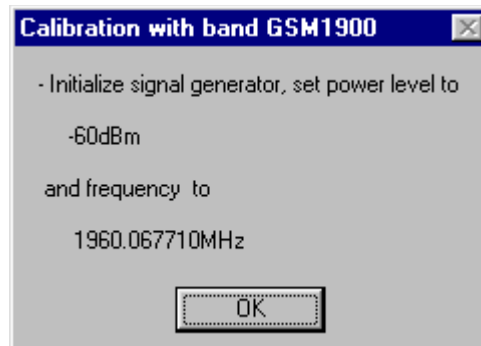

Connect an external signal generator to the RF connector of the phone and compensate for the external RF cable losses. Set the generator as shown in the window above. If a radio communication tester (CMD55, CMU200, 8960, MT8801) is used, assure to have continuous mode switched on and modulation switched off.

Press OK and the window closes.

A typical result will look like this:

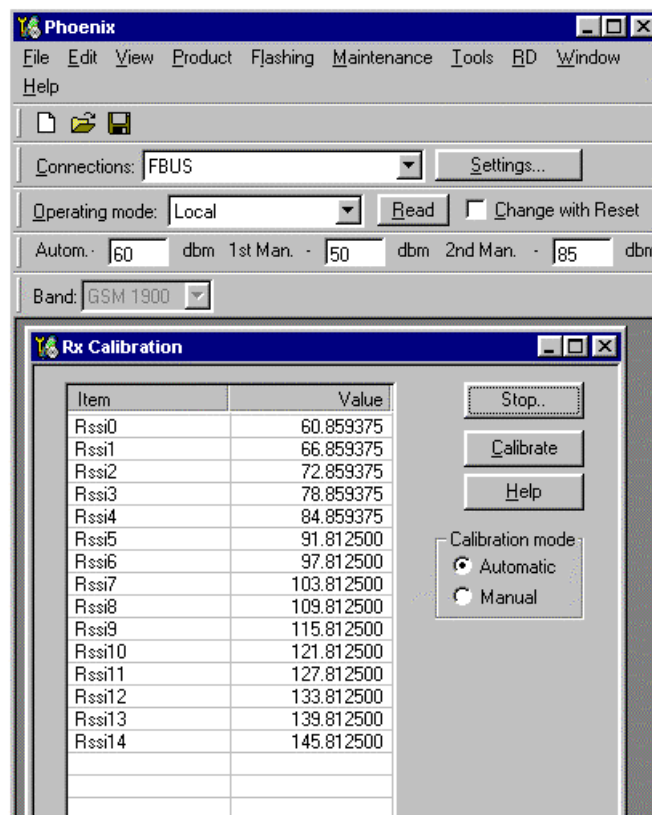

The results must be compared with the following limits:

Value	Typical	Limit min.	Limit max.
Rssi 3	78	76	81
Rssi 6	98	96	101

If Rssi 3 and Rssi 6 are within the limits, all other Rssi values are valid, too. If not, continue according to the instructions of RX Fault finding flow chart.

Press Stop in the RX Calibration window and a new window pops up:

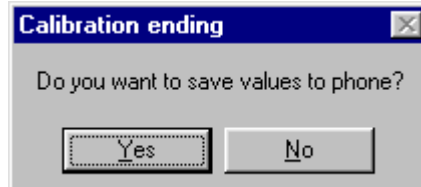

Press Yes and the GSM1900 RX Calibration is finished.

### RX Band Filter Response Compensation

This alignment is necessary to compensate the frequency response of the RX band filters (SAW filters).

#### RX Band Filter Response EGSM900 (EGSM)

Set operating mode to local mode.

Select	Maintenance		Alt-M
	Tuning		T
		RF Controls	F

Wait until the RF Controls window pops up.

Select	Band	GSM 900	
Select	Maintenance		Alt-M
	Tuning		T
		RX Band Filter Response Compensation	B

A window pops up:

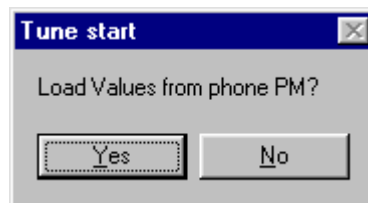

Select Yes and the RX Band Filter Response Compensation window pops up.

The setup should now look like this:

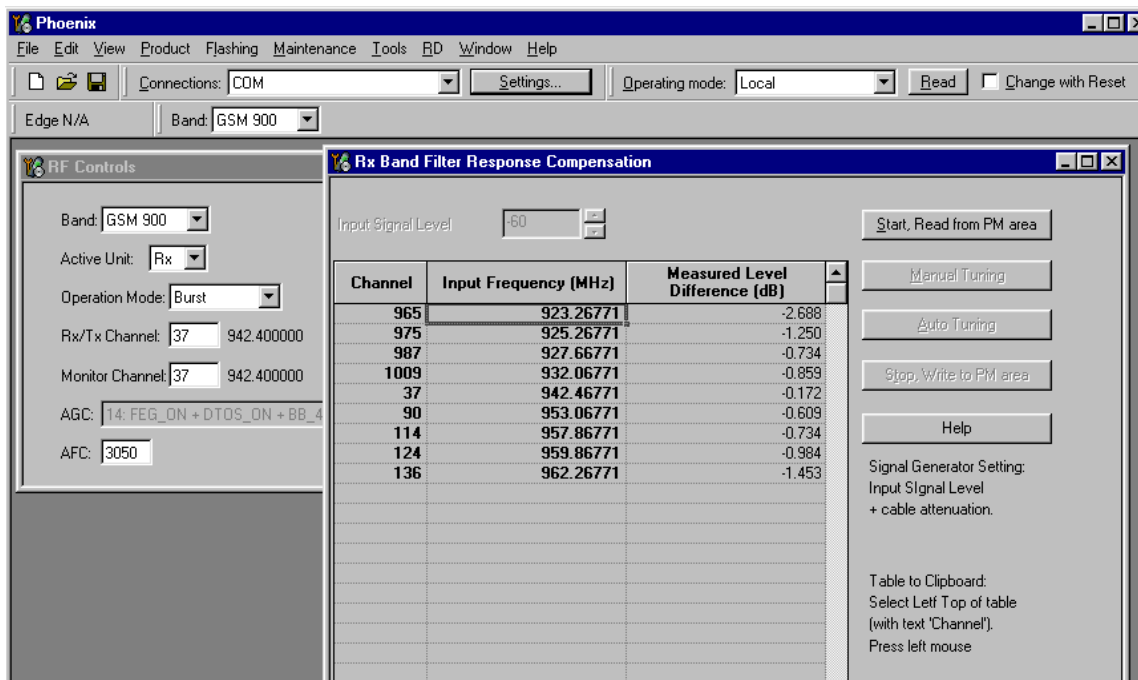

Select Input Signal Level -60dBm

### Manual Tuning

Press Manual Tuning and a window pops up:

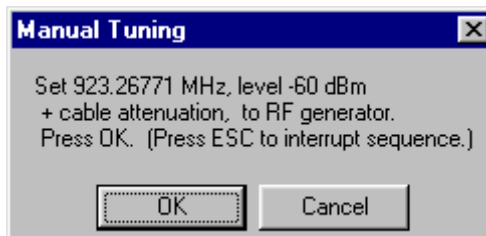

Connect an external signal generator to the RF connector of the phone and compensate for the external RF cable losses. Set the generator as shown in the window, above. If a radio communication tester (CMD55, CMU200, 8960, MT8801) is used, assure to have continuous mode switched on and modulation switched off.

Press OK and a new window pops up:

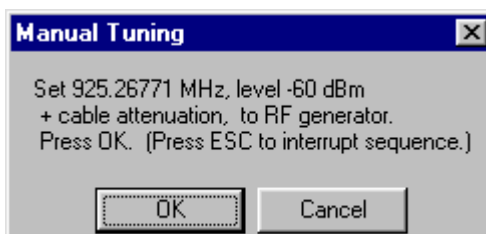

Set the generator as shown in the window above.

Press OK and a new window pops up. Continue with the sequence until the calibration is finalized on all of the 9 channels.



Press Stop, Write to PM Area (In the RX Band Filter Response Compensation window) and a window pops up:

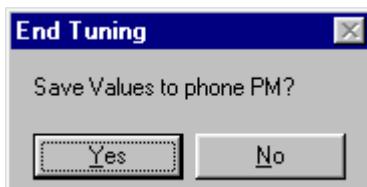

Press Yes and the EGSM RX Band Filter Response Compensation is finished.

### Auto Tuning

A faster and more convenient method for Band Filter Calibration can be performed by clicking on "Auto Tuning". This requires a Signal Generator that can be pre-programmed to sweep through user defined frequencies.

Program the signal generator according to the list of frequencies that is shown in the window's column "Input Frequency (MHz)".

Press Auto Tuning and a window pops up:



Connect an external signal generator to the RF connector of the phone and the signal generator will generate the pre-programmed frequencies after pressing: OK.

Press Stop, Write to PM Area (In the RX Band Filter Response Compensation window) and a window pops up:

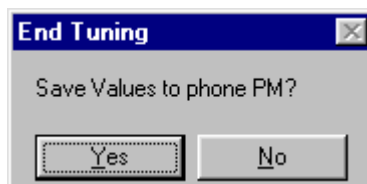

Press Yes and the EGSM RX Band Filter Response Compensation is finished.

### Limits

Regarding the limits, the value of N4 is given below. Concerning the other filter frequencies please refer to Appendix A where all FLALI testcases are listed together with the limits.

Value	Typical	Limit min.	Limit max.
N4	0	-0.3	0.3

## RX Band Filter Response GSM1800 (DCS/PCN)

Set operating mode to local mode.

Select Maintenance Tuning RF Controls Alt-M  
T  
F

Wait until the RF Controls window has popped up

Select Band GSM 1800

Select Maintenance Tuning RX Band Filter Response Compensation Alt-M  
T  
B

The following window pops up:

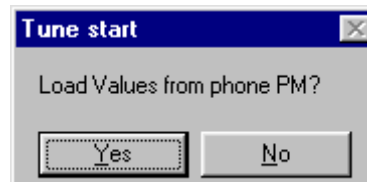

Select Yes and the RX Band Filter Response Compensation window pops up.

The setup should now look like this:

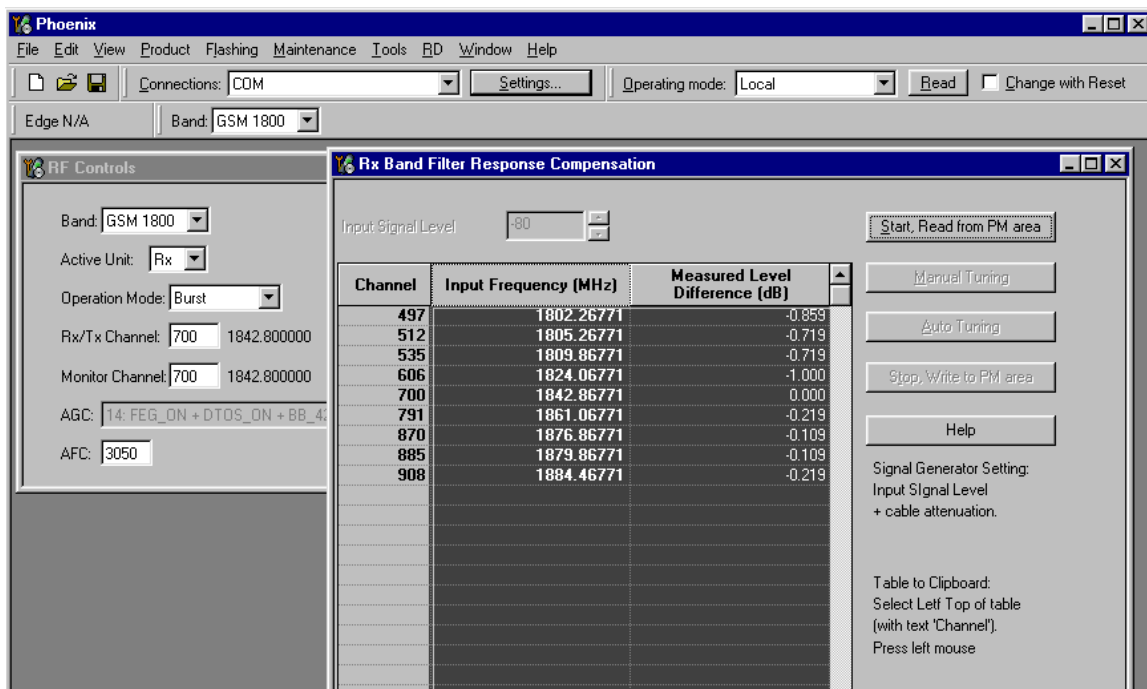

Select Input Signal Level -60dBm

### Manual Tuning

Press Manual Tuning and a window pops up:

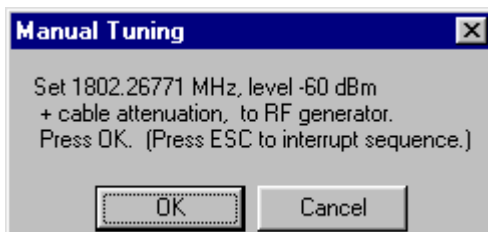

Connect an external signal generator to the RF connector of the phone and compensate for the external RF cable losses. Set the generator as shown in the window above. If a radio communication tester (CMD55, CMU200, 8960, MT8801) is used, assure to have continuous mode switched on and modulation switched off.

Press OK and a new window pops up:

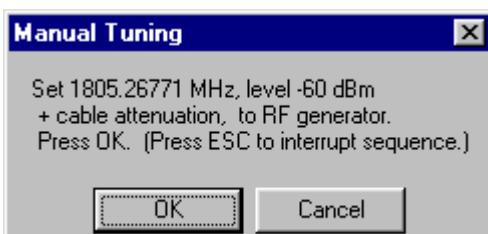

Set the generator as shown in the window above.

Press OK and a new window pops up. Repeat this sequence until the calibration is finalized on all of the 9 channels.

Press Stop, Write to PM Area (In the RX Band Filter Response Compensation window) and a window pops up:

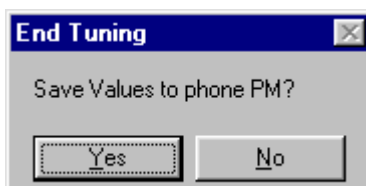

Press Yes and the GSM1800 RX Band Filter Response Compensation is finished.

### Auto Tuning

A faster and more convenient method for Band Filter Calibration can be performed by clicking on "Auto Tuning". This requires a Signal Generator that can be pre-programmed to sweep through user defined frequencies.

Program the signal generator according to the list of frequencies that is shown in the window's column "Input Frequency (MHz)".

Press Auto Tuning and a window pops up:



Connect an external signal generator to the RF connector of the phone and the signal generator will generate the pre-programmed frequencies after pressing OK.

Press Stop, Write to PM Area (In the RX Band Filter Response Compensation window) and a window pops up:

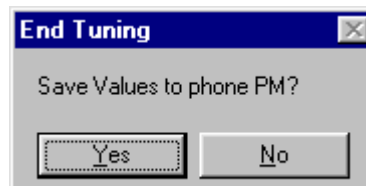

Press Yes and the EGSM RX Band Filter Response Compensation is finished.

#### Limits

Regarding limits the value for N4 is given below. Concerning the other filter frequencies please refer to Appendix A where all FLALI testcases are listed together with the limits.

Value	Typical	Limit min.	Limit max.
N4	0	-0.3	0.3

#### RX Band Filter Response GSM1900 (PCS)

Set operating mode to local mode

Select	Maintenance	Alt-M
	Tuning	T
	RF Controls	F

Wait until the RF Controls window pops up

Select	Band	GSM 1900
--------	------	----------

Select	Maintenance	Alt-M
	Tuning	T
	RX Band Filter	B
	Response Compensation	

A window pops up:

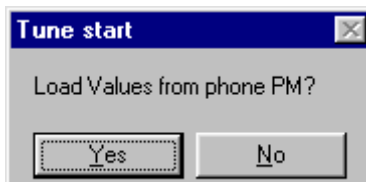

Select Yes and the RX Band Filter Response Compensation window pops up.

The setup should now look like this:

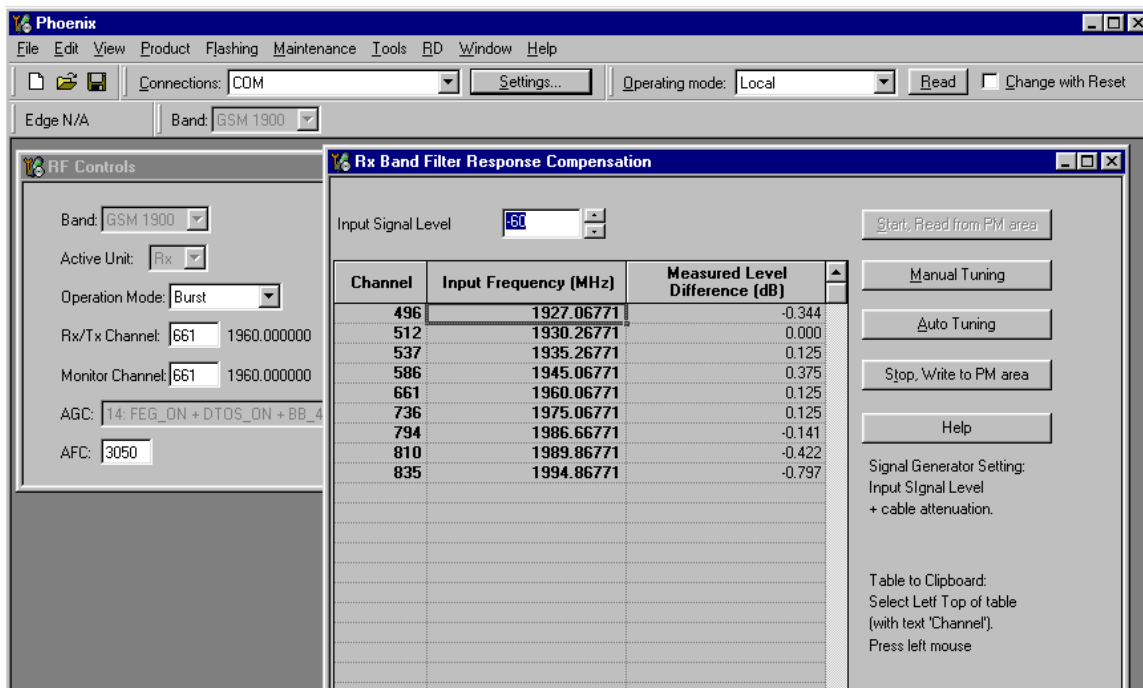

Select Input Signal Level -60dBm

### Manual Tuning

Press Manual Tuning and a window pops up:

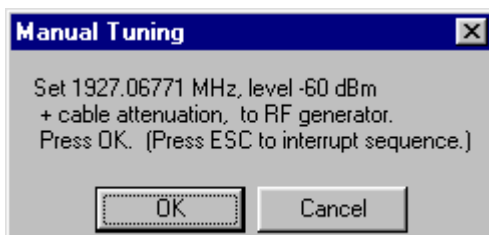

Connect an external signal generator to the RF connector of the phone and compensate for the external RF cable losses. Set the generator as shown in the window above. If a radio communication tester (CMD55, CMU200, 8960, MT8801) is used, assure to have continuous mode switched on and modulation switched off.

Press OK and a new window pops up:

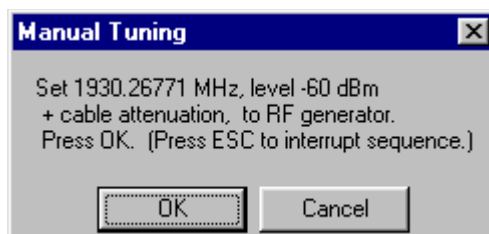

Set the generator as shown in the window above.

Press OK and a new window pops up. Continue the sequence until the calibration is finalized on all 9 channels.

Press Stop, Write to PM Area (In the RX Band Filter Response Compensation window) and a window pops up:

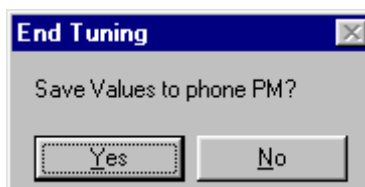

Press Yes and the GSM1900 RX Band Filter Response Compensation is finished.

### Auto Tuning

A faster and more convenient method for Band Filter Calibration can be performed by clicking on "Auto Tuning". This requires a signal Generator that can be pre-programmed to sweep through user defined frequencies.

Program the signal generator according to the list of frequencies that is visible in the window's column "Input Frequency (MHz)".

Press Auto Tuning and a window pops up:



Connect an external signal generator to the RF connector of the phone and the signal generator will generate the programmed frequencies after pressing OK.

Press Stop, Write to PM Area (In the RX Band Filter Response Compensation window) and a window pops up:

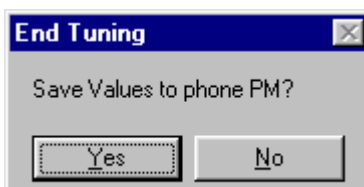

Press Yes and the EGSM RX Band Filter Response Compensation is finished.

Limits

Regarding the limits, the value of N4 is given below. Concerning the other filter frequencies please refer to Appendix A where all FLALI testcases are listed together with the limits.

Value	Typical	Limit min.	Limit max.
N4	0	-0.3	0.3

**RX Channel Select Filter Calibration**

In the following the calibration of the Base Band filter inside Mjoelner is described. It is performed by internally measuring of a prototype filter. For this reason the calibration is done only once, and not separately in 3 bands.

Set operating mode to local mode

Select	Maintenance	Alt-M
	Tuning	T
	RX Channel Select filter Calibration	H

A window pops up:

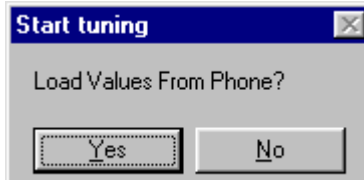

Select Yes and the RX Channel Select Filter Calibration window pops up.

The setup should now look like this:

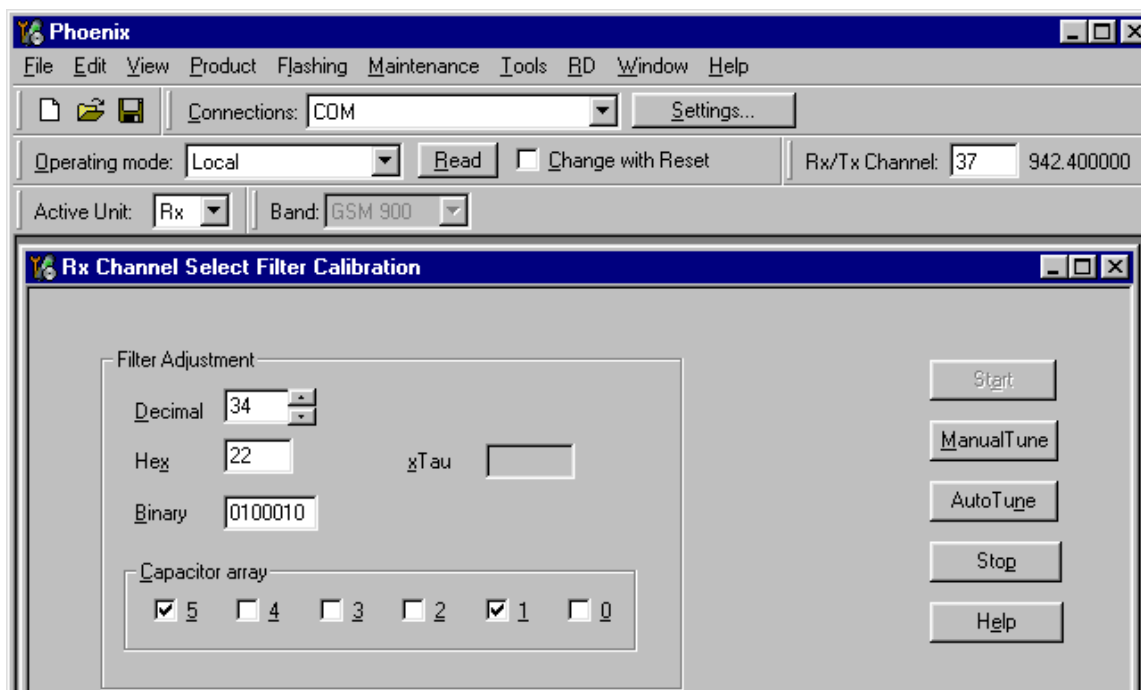

Press Auto Tune and the optimal values are found.

Press Stop and a new window pops up:

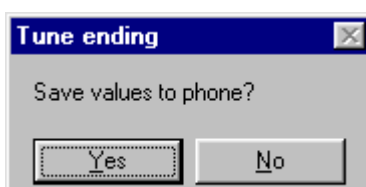

Press Yes and the RX Channel Select Filter Calibration is finished.

Limits of the GTR value = Filter adjustment value in "decimal" format:

Value	Typical	Limit min.	Limit max.
GTR	34	28	40

## RX AM Suppression

The RH-19 RFIC Mjoelner does not require any tuning of AM suppression.

## TX Power Level Tuning

This tuning must be done in all three bands.

**Note:** TX Power Tuning must be done with a peak power meter, e.g. Anritsu model ML2408A with Anritsu Peak Power Sensor MA2442A and a suitable attenuator.

The use of the built-in power meter of GSM testers is likely to cause larger errors than the use of a dedicated power meter and might cause miss tuning so that the phone might be not compliant with the GSM specifications.



Set power supply voltage Vcc=3.6V!

### TX Power Level Tuning EGSM (EGSM900)

Set operating mode to local mode.

Select Maintenance  
Tuning  
TX Power Level Tuning

Wait until the TX Power Level Tuning window has popped up.

Connect a **calibrated** power meter to the RF connector of the phone.

Select Band GSM 900  
Active Unit TX

Press Start and a window pops up:

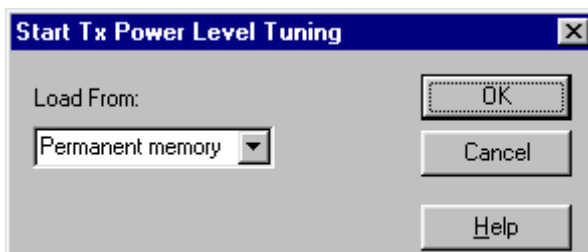

Select Permanent memory, press OK and the window closes.

Select TX Data Type Random

The setup should now look like this:

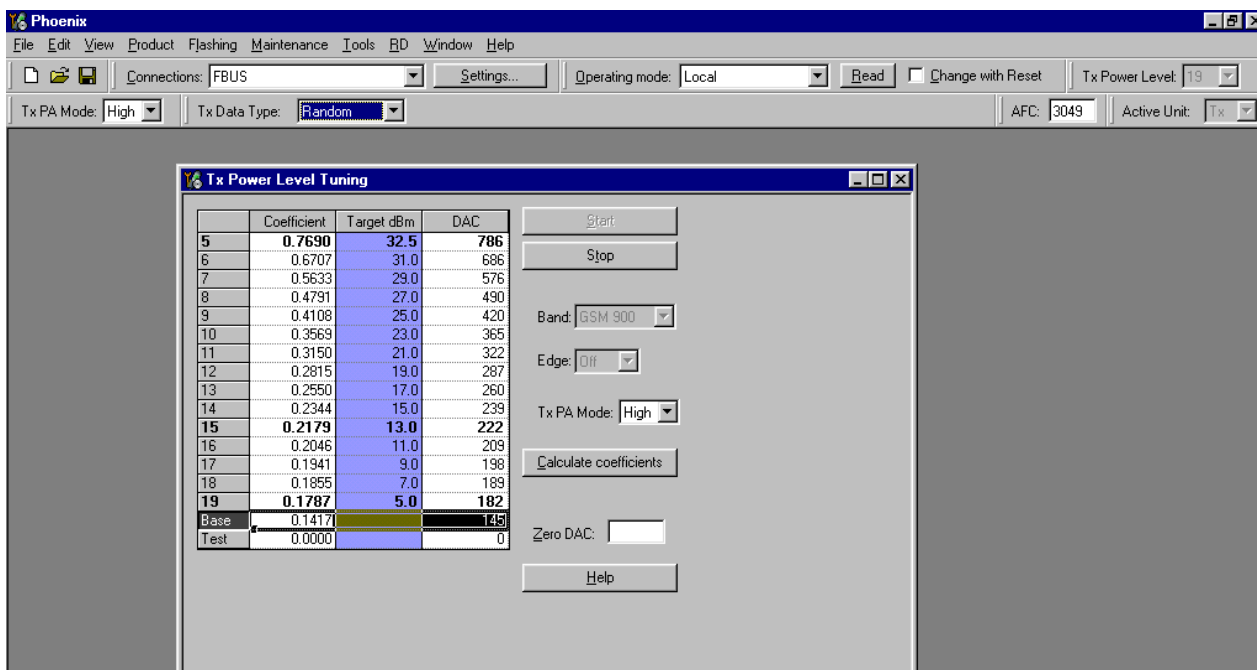

Select TX PA Mode High

Adjust DAC Values in TX PA mode 'High' for all power levels according to the target values:

TX PA Mode	Power level	Target power (dBm)
High	5	32.5
	15	13
	19	5
	Base level	-27

The power levels may differ from the target power levels in Phoenix.

Make sure that the output power for Power Level 5 is equal or lower than 1dB below the saturation output power. Determine the saturation power by setting the DAC Value to its maximum, for example, adjust the DAC Value to 32.3dBm for Power Level 5 if the saturation output power is only 33.3dBm.

Press calculate, check if all levels match the target values, correct if necessary.

Select TX PA Mode Low

Adjust DAC Values in TX PA mode 'Low' for all power levels according to the target values.

TX PA Mode	Power level	Target power (dBm)
Low	7	30
	15	13
	19	5
	Base level	-27

Press calculate, check if all levels match the target values, correct if necessary.

Press Stop and a window pops up:

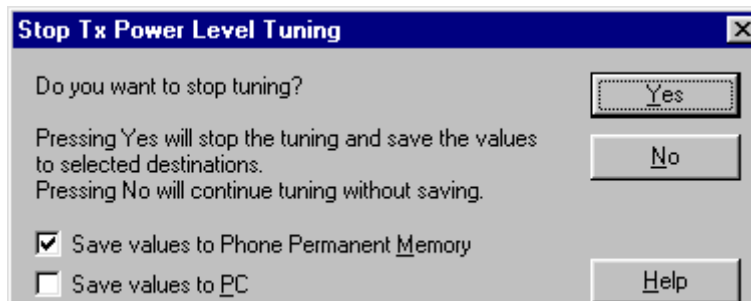

Select 'Save values to Phone Permanent Memory'

Press Yes and the EGSM TX Power Level Tuning is finished.

### TX Power Level Tuning GSM1800 (DCS/PCN)

Set operating mode to local mode

Select Maintenance Tuning TX Power Level Tuning

Wait until the TX Power Level Tuning window has popped up.

Connect a **calibrated** power meter to the RF connector of the phone.

Select Band GSM 1800  
Active Unit TX

Press Start and a window pops up:

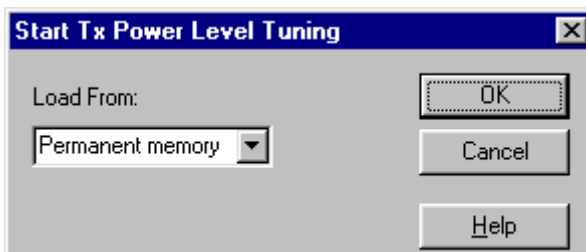

Select Permanent memory, press OK and the window closes.

Select TX Data Type Random

The setup should now look like this:

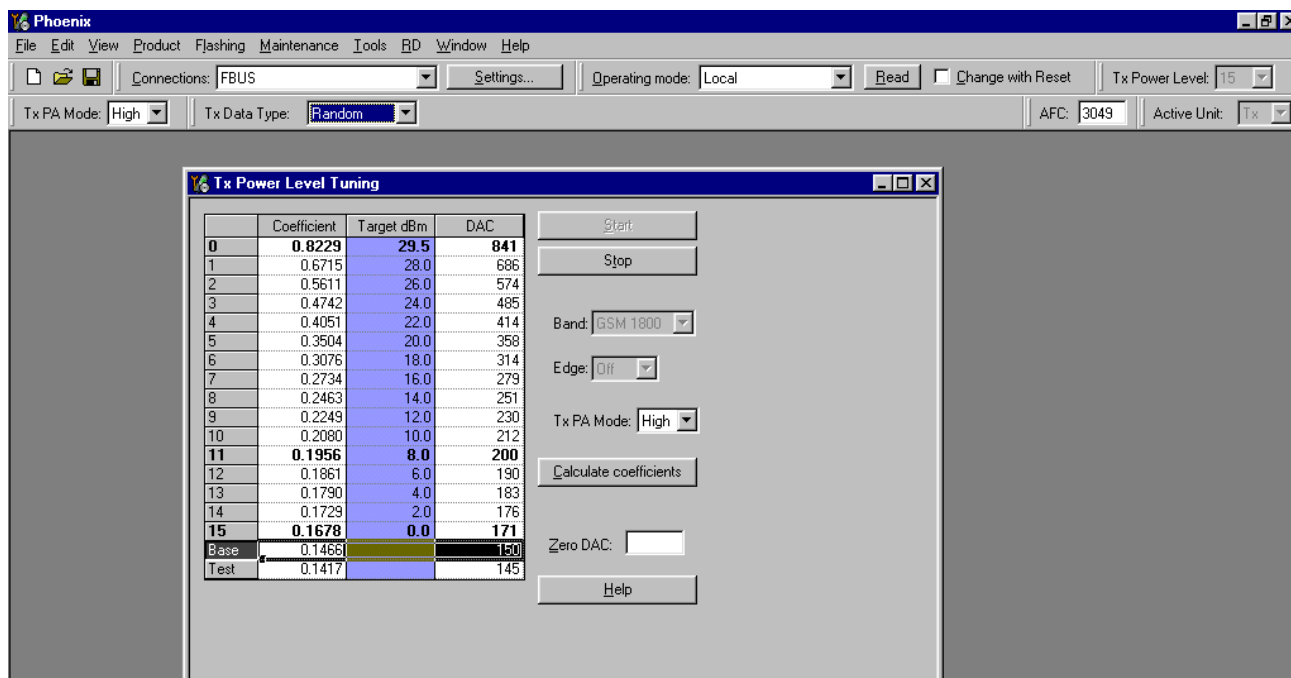

Select TX PA Mode High

Adjust DAC Values for all power levels according to the target values.

Power level	Power (dBm)
0	30
11	8
15	0
Base level	-27

The Power levels may differ from the target levels mentioned. Make sure that the output power for Power Level 0 is equal or lower than 1dB below the saturation output power. Determine the saturation power by setting the DAC Value to its maximum, for example, adjust the DAC Value to 29.7dBm for Power Level 0 if the saturation output power is only 30.7dBm.

Press calculate, check if all levels match the target values, correct if necessary.

Press Stop and a window pops up:

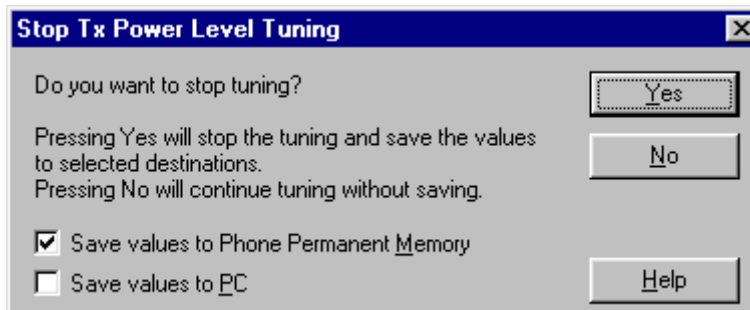

Select Save values to Phone Permanent Memory

Press Yes and the GSM1800 TX Power Level Tuning is finished.

### TX Power Level Tuning GSM1900 (PCS)

Set operating mode to local mode.

Select Maintenance  
Tuning  
TX Power Level Tuning

Wait until the TX Power Level Tuning window pops up.

Connect a **calibrated** power meter to the RF connector of the phone.

Select Band GSM 1900  
Active Unit TX

Press Start and a window pops up:

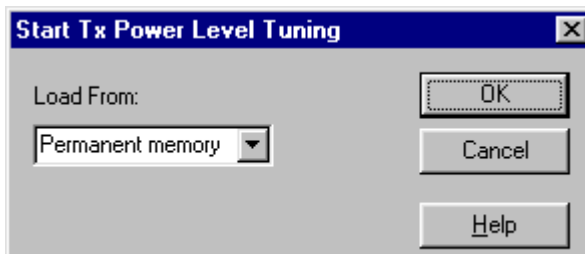

Select Permanent memory, press OK and the window closes.

Select TX Data Type Random

The setup should now look like this:

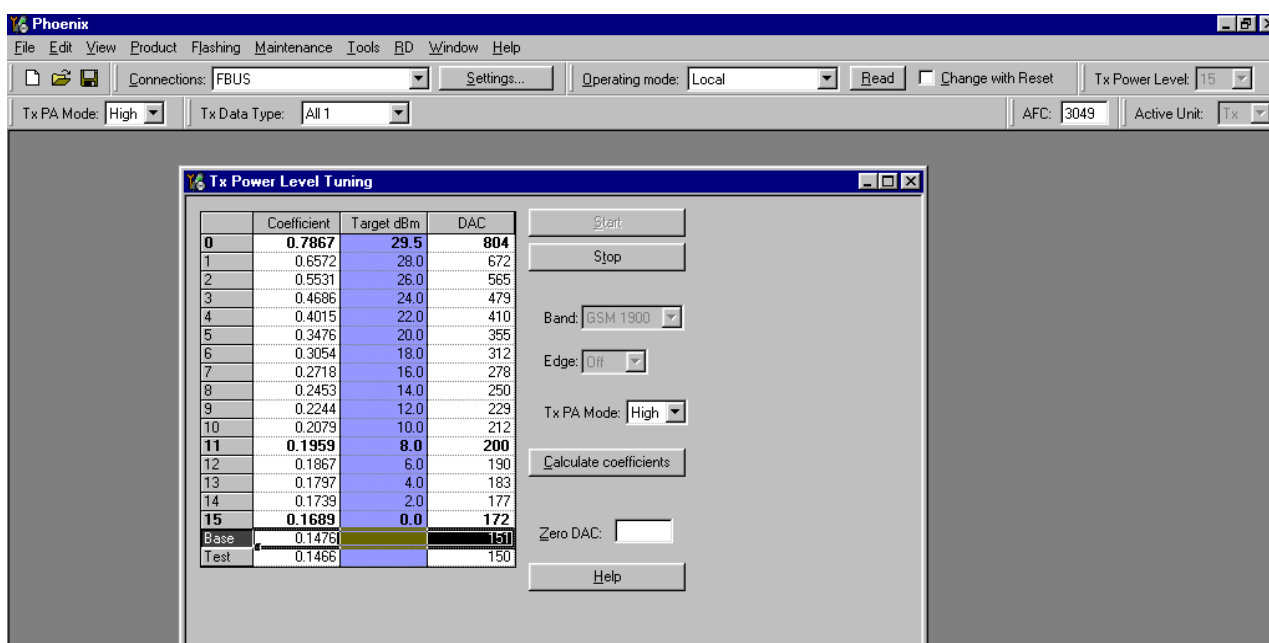

Select TX PA Mode High

Adjust DAC Values for all power levels according to the target values.

Power level	Power (dBm)
0	30
11	8
15	0
Base level	-27

The Power levels may differ from the target poer levels mentioned in Phoenix. Make sure that the output power for Power Level 0 is equal or lower than 1dB below the saturation output power. Determine the saturation power by setting the DAC Value to its maximum, for example, adjust the DAC Value to 29.7dBm foe Power Level 0 if the saturation output power is only 30.7dBm.

Press calculate, check if all levels match the target values, correct if necessary.

Press Stop and a window pops up:

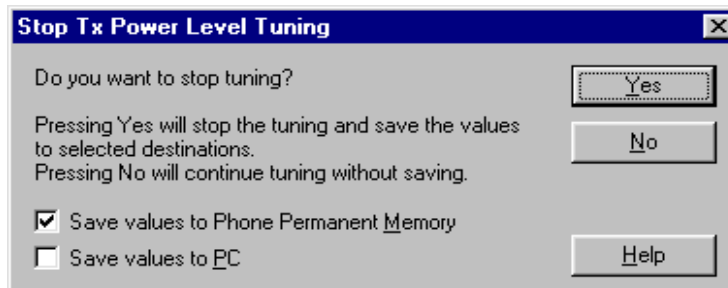

Select Save values to Phone Permanent Memory.

Press Yes and the GSM1900 TX Power Level Tuning is finished.

## TX I/Q Tuning

This tuning must be performed in all three bands.

### TX I/Q Tuning GSM900

**Caution:** If you use a spectrum analyzer make sure that the external attenuation between phone and spectrum analyzer is high enough that the input of the analyzer can't be destroyed, 20 to 30dB is recommended. Adjust the reference level offset according to the insertion loss between the phone and the spectrum analyzer.

**Note:** During TX I/Q Tuning in EGSM900 band, an additional calibration value for the battery voltage A/D converter is taken. Therefore it is important to set the operating voltage to 3.6V for this alignment.

#### PC/Phone operation:

Set operating mode to Local Mode.

Set supply voltage to 3.6V.

Select	Maintenance	Alt-M
	Tuning	T
	TX IQ Tuning	I

Wait until the TX IQ Tuning window pops up.

Select	Maintenance	Alt-M
	Tuning	T
	RF Controls	F

Wait until the RF Controls window pops up.

Connect a Spectrum Analyzer or GSM tester with the option 'Narrow Spectrum' to the antenna pads of the phone.

If a spectrum analyzer is used, make the following settings.

	<b>EGSM/EGSM900</b>
<b>Center Frequency</b>	897.4 MHz
<b>Frequency Span</b>	300 kHz
<b>Resolution Bandwidth</b>	3kHz
<b>Video Bandwidth</b>	3kHz
<b>Sweep Time</b>	3 sec.
<b>Sweep Type</b>	Clear/Write
<b>Detector Type</b>	Max Peak
<b>Reference level</b>	35 dBm
<b>Marker 1</b>	897.33229 MHz
<b>Marker 2</b>	897.4 MHz
<b>Marker 3</b>	897.46771 MHz

Select in the RF Controls Window:

Select	Band	GSM 900
	Active Unit	TX
	Operation Mode	Burst
	RX/TX Channel	37
	TX PA Mode	Free
	TX Data Type	All1

Select in the TX IQ Tuning Window:

Select  Load from Product

Press Start

Select again in the RF Controls Window:

Select TX Power Level 9

The setup should now look like this:

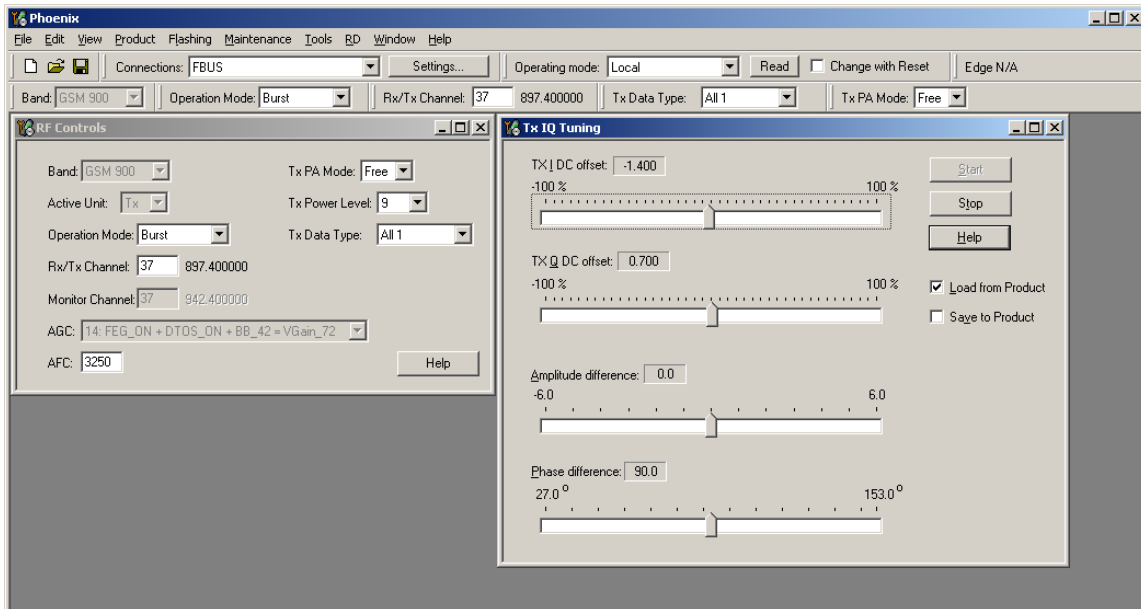

The Spectrum Analyzer now shows a plot like this:

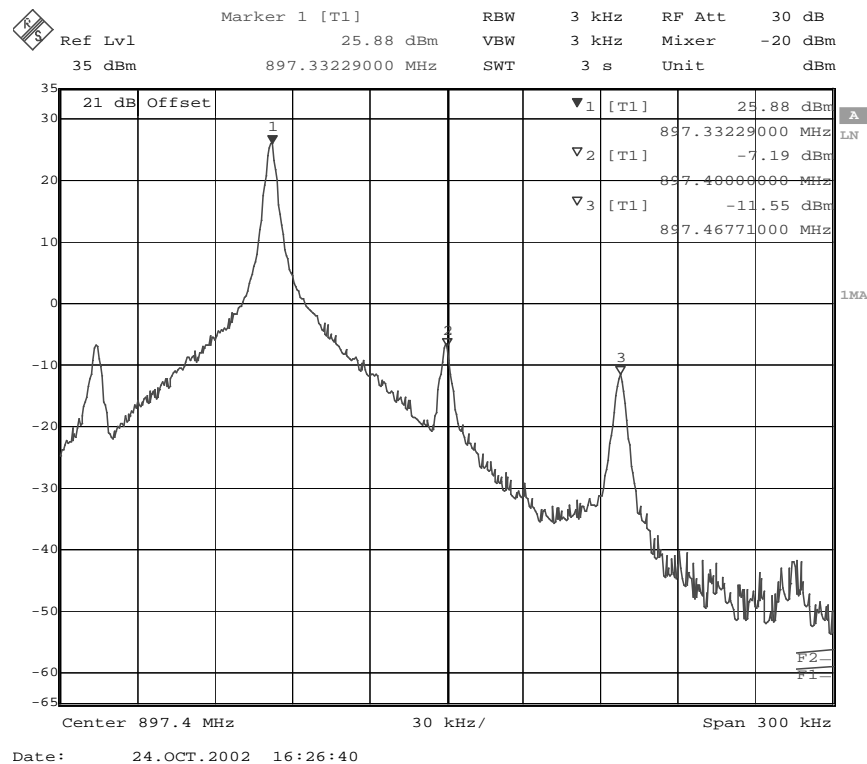

The purpose of this alignment is to tune the carrier signal (at marker 2) and the +67kHz signal (at marker 3) to a minimum level.

Use the variables 'TX I DC offset' and 'TX Q DC offset' to adjust the carrier signal to a minimum level (marker 2). Tuning can be performed by using arrow keys on the keyboard. Pushing the sliders by using the mouse is less sensitive however possible.



After tuning to the minimum the level difference between marker 2 and the peak levels at marker 1 must exceed 40dB.

The Spectrum Analyzer now shows a plot like this:

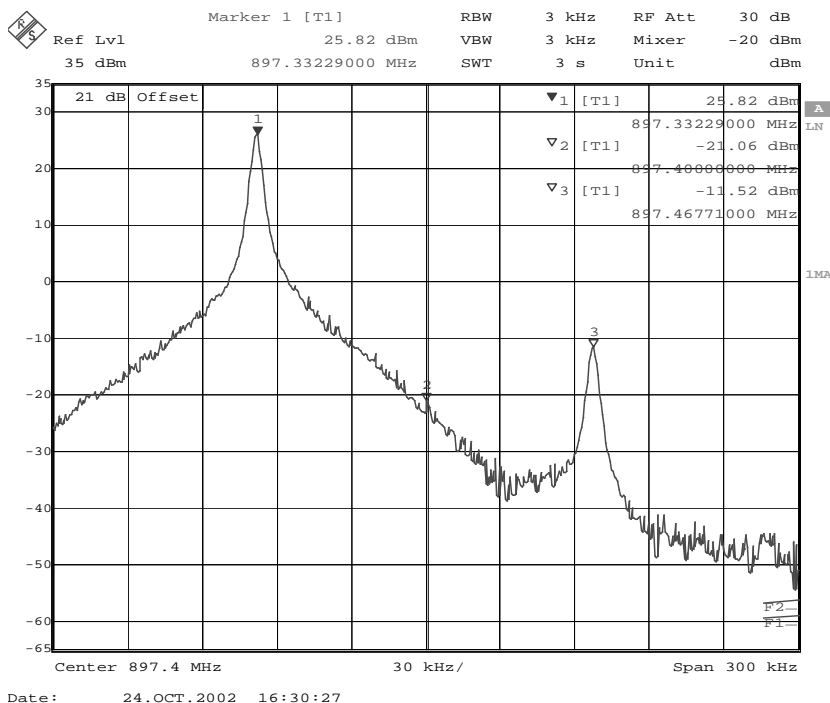

Use the variables 'Amplitude difference' and 'Phase difference' to adjust the +67kHz signal to a minimum level (Marker 3). Tuning can be performed by using the arrow keys on the keyboard. Pushing the sliders by using the mouse is less sensitive however possible.

After tuning to the minimum the level difference between marker 3 and the peak level at marker 1 must exceed 40dB.

The Spectrum Analyzer now shows a plot like this:

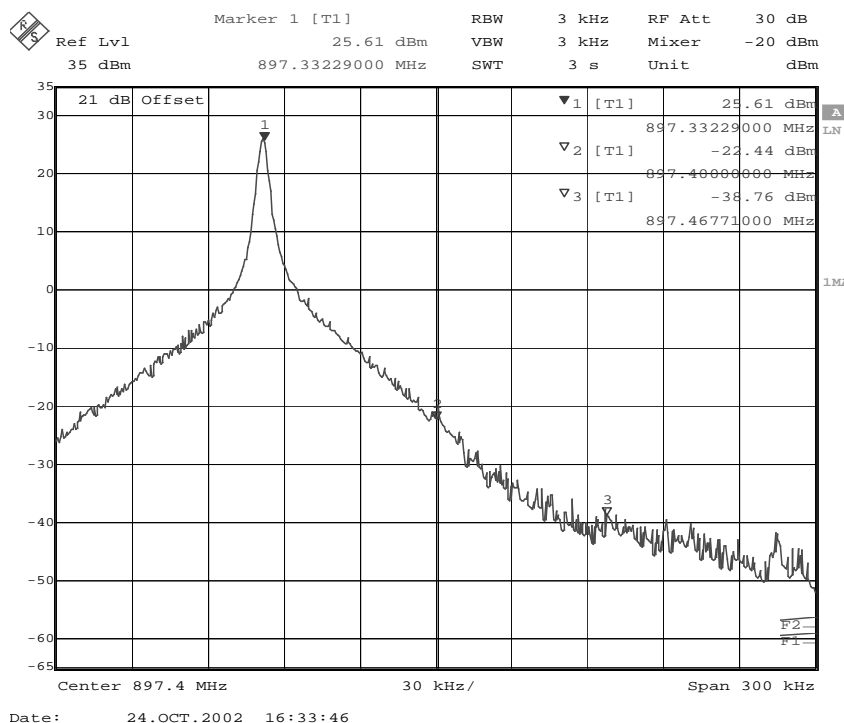

Compare the results in the TX IQ Tuning Window with the limits below:

Value	Typical	Limit min.	Limit max.
TX I DC offset	0.1	-6	6
TX Q DC offset	0	-6	6
Amplitude difference	0	-1	1
Phase difference	87.5	80	100

Select in the TX IQ Tuning Window:

Select  Save to Product

Press Stop

and the values are stored in the phone. The GSM900 TX IQ Tuning is now finished.

Note: The optimum values for "TX I and Q Offset" and "Amplitude and Phase Difference" vary from phone to phone.

### TX I/Q Tuning GSM1800

**Caution:** If you use a spectrum analyzer make sure that the external attenuation between phone and spectrum analyzer is high enough that the input of the analyzer can't be destroyed, 20 to 30dB is recommended. Adjust the reference level offset according to the insertion loss between the phone and the spectrum analyzer.

PC/Phone operation:

Set operating mode to Local Mode.

Select	Maintenance	Alt-M
	Tuning	T
	TX IQ Tuning	I

Wait until the TX IQ Tuning window has popped up.

Select	Maintenance	Alt-M
	Tuning	T
	RF Controls	F

Wait until the RF Controls window has popped up.

Connect a Spectrum Analyzer or GSM tester with the option 'Narrow Spectrum' to the RF connector of the phone.

If a spectrum analyzer is used, make the following settings.

	<b>GSM1800</b>
<b>Center Frequency</b>	1747.8MHz
<b>Frequency Span</b>	300 kHz
<b>Resolution Bandwidth</b>	3 kHz
<b>Video Bandwidth</b>	3 kHz
<b>Sweep Time</b>	3 sec.
<b>Sweep Type</b>	Clear/Write
<b>Detector Type</b>	Max Peak
<b>Reference level</b>	35 dBm
<b>Marker 1</b>	1747.73229 MHz
<b>Marker 2</b>	1747.8 MHz
<b>Marker 3</b>	1747.86771 MHz

Select in the RF Controls Window:

Select	Band	GSM 1800
	Active Unit	TX
	Operation Mode	Burst
	RX/TX Channel	700
	TX PA Mode	Free
	TX Data Type	All1

Select in the TX IQ Tuning Window:

Select	<input checked="" type="checkbox"/> Load from Product
Press	Start

Select again in the RF Controls Window:

Select	TX Power Level 4
--------	------------------

The setup should now look like this:

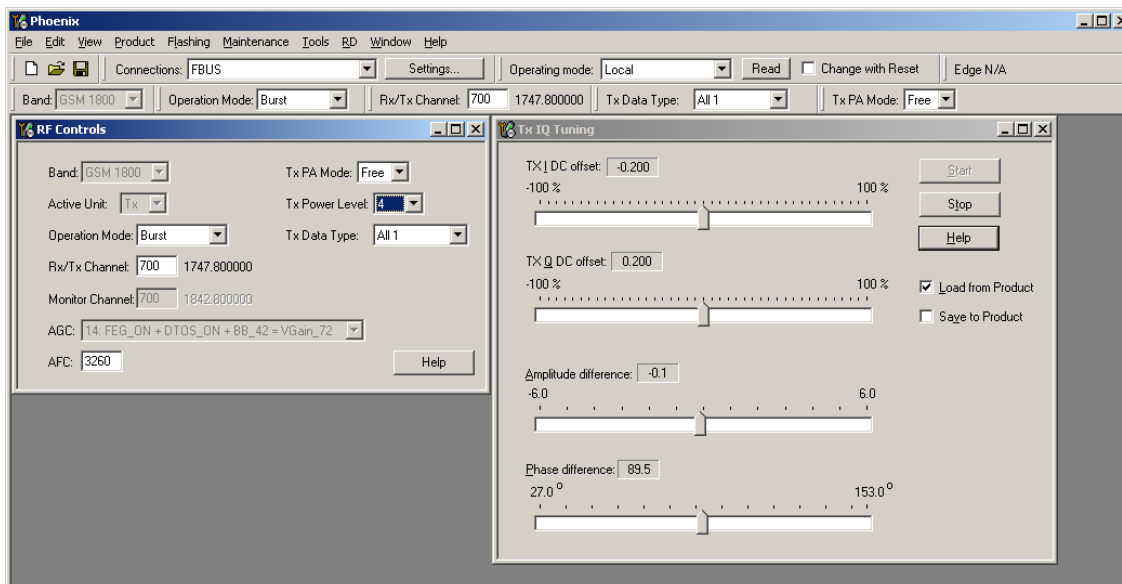

The Spectrum Analyzer now shows a plot like this:

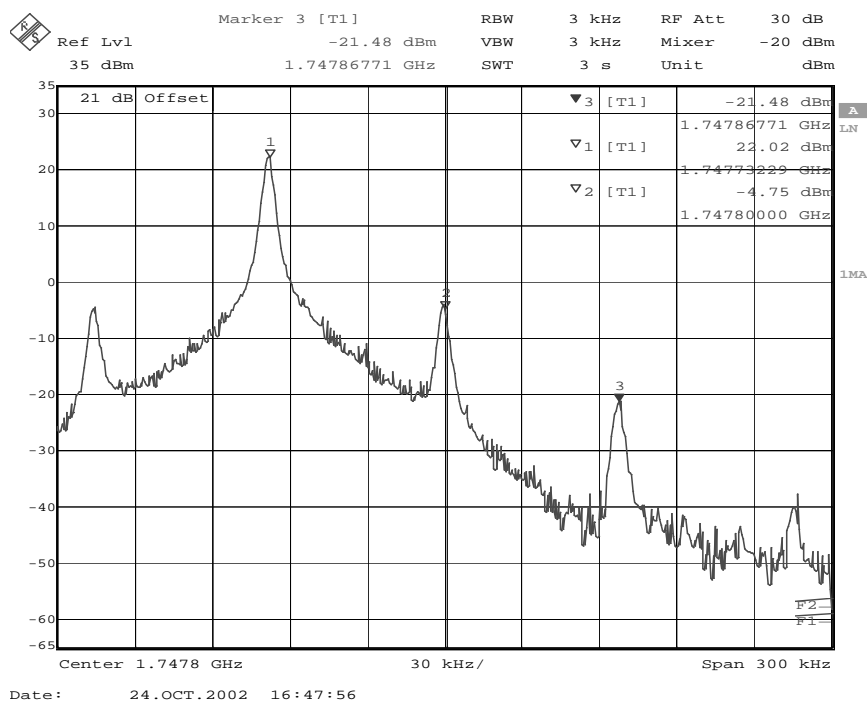

The purpose of this alignment is to tune the carrier signal (at marker 2) and the +67kHz signal (at marker 3) to a minimum level.

Use the variables 'TX I DC offset' and 'TX Q DC offset' to adjust the carrier signal to a minimum level (Marker 2). Tuning is possible by using arrow keys on the keyboard. Pushing the sliders by using the mouse is less sensitive but even possible.

After tuning to the minimum the level difference between marker 2 and the peak levels at marker 1 must exceed 40dB.

The Spectrum Analyzer now shows a plot like this:

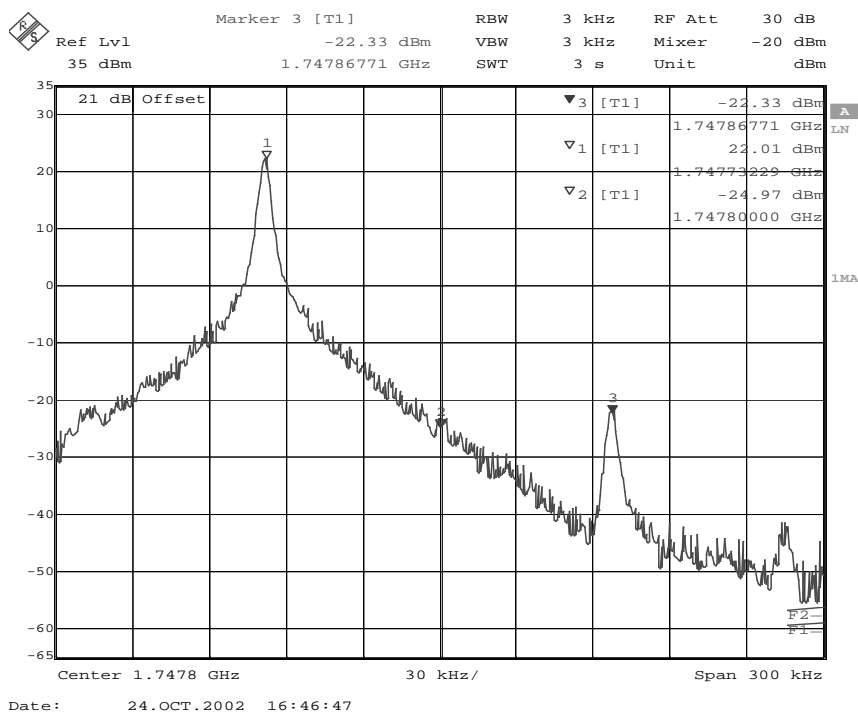

Use the variables 'Amplitude difference' and 'Phase difference' to adjust the +67kHz signal to a minimum level (Marker 3). Tuning can be performed by using the arrow keys on the keyboard. Pushing the sliders by using the mouse is less sensitive however possible.

After tuning to the minimum the level difference between marker 3 and the peak level at marker 1 must exceed 40dB.

The Spectrum Analyzer now shows a plot like this:

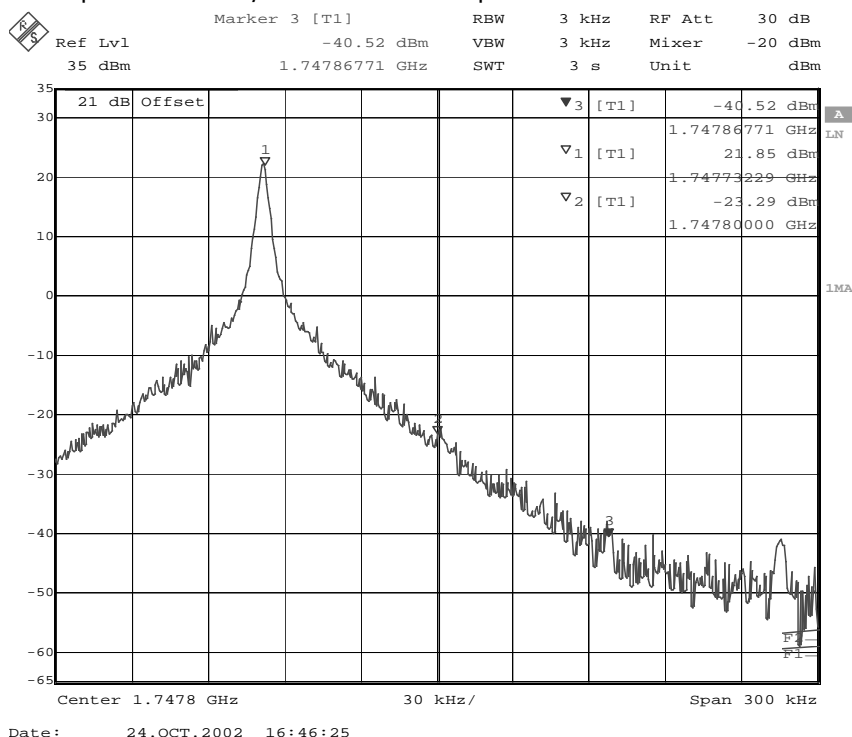

Compare the results in the TX IQ Tuning Window with the limits below:

Value	Typical	Limit min.	Limit max.
TX I DC offset	0.1	-6	6
TX Q DC offset	-0.1	-6	6
Amplitude difference	-0.1	-1	1
Phase difference	89.5	80	100

Select in the TX IQ Tuning Window:

Select  Save to Product

Press Stop

and the values are stored in the phone. The GSM1800 TX IQ Tuning is now finished.

Note: The optimum values for "TX I and Q Offset" and "Amplitude and Phase Difference" vary from phone to phone.

### TX I/Q Tuning GSM1900

**Caution:** If you use a spectrum analyzer make sure that the external attenuation between phone and spectrum analyzer is high enough that the input of the analyzer can't be destroyed, 20 to 30dB is recommended. Adjust the reference level offset according to the insertion loss between the phone and the spectrum analyzer.

#### PC/Phone operation:

Set operating mode to local mode

Select Maintenance Alt-M  
Tuning T  
TX IQ Tuning I

Wait until the TX IQ Tuning window has popped up.

Select Maintenance Alt-M  
Tuning T  
RF Controls F

Wait until the RF Controls window has popped up.

Connect a Spectrum Analyzer or GSM tester with the option 'Narrow Spectrum' to the RF connector of the phone.

If a spectrum analyzer is used, make the following settings.

	GSM1900
Center Frequency	1880MHz
Frequency Span	300 kHz
Resolution Bandwidth	3 kHz
Video Bandwidth	3 kHz

<b>Sweep Time</b>	3 sec.
<b>Sweep Type</b>	Clear/Write
<b>Detector Type</b>	Max Peak
<b>Reference level</b>	35 dBm
<b>Marker 1</b>	1879.93229 MHz
<b>Marker 2</b>	1880 MHz
<b>Marker 3</b>	1880.06771 MHz

Select in the RF Controls Window:

Select                      Band                      GSM 1900  
                                  Active Unit                      TX  
                                  Operation Mode                      Burst  
                                  RX/TX Channel                      661  
                                  TX PA Mode                      Free  
                                  TX Data Type                      All1

Select in the TX IQ Tuning Window:

Select                       Load from Product  
 Press                      Start

Select again in the RF Controls Window:

Select                      TX Power Level 4

The setup should now look like this:

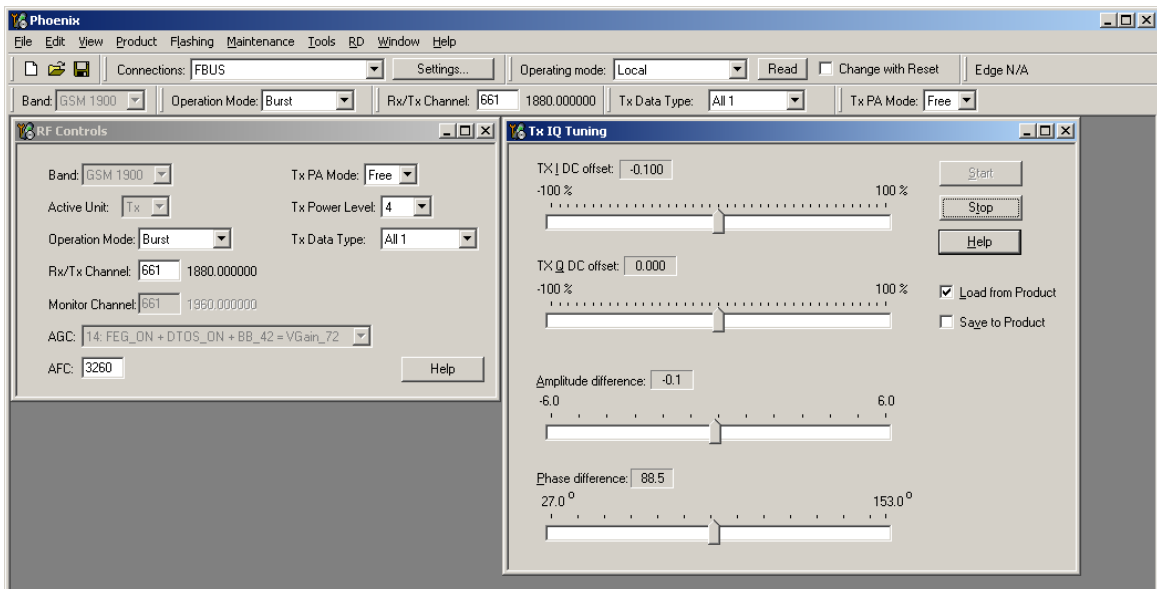

The Spectrum Analyzer now shows a plot like this:

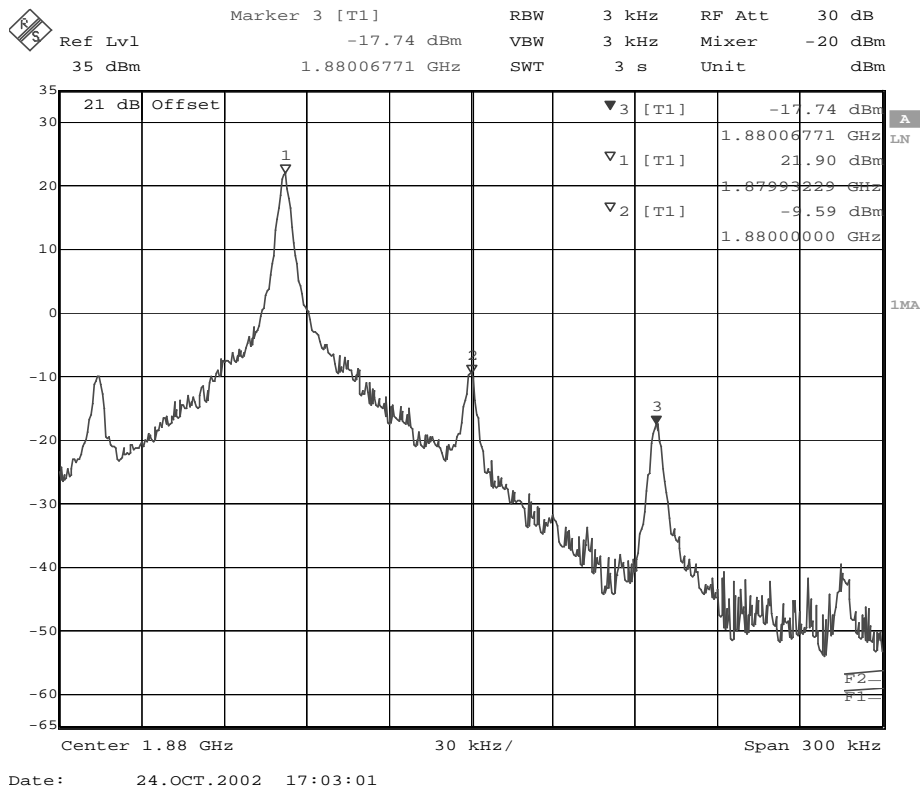

The purpose of this alignment is to tune the carrier signal (at marker 2) and the +67kHz signal (at marker 3) to a minimum level.

Use the variables 'TX I DC offset' and 'TX Q DC offset' to adjust the carrier signal to a minimum level (marker 2). Tuning can be performed by using arrow keys on the keyboard. Pushing the sliders by using the mouse is less sensitive however possible.

After tuning to the minimum the level difference between marker 2 and the peak levels at marker 1 must exceed 40dB.



The Spectrum Analyzer now shows a plot like this:

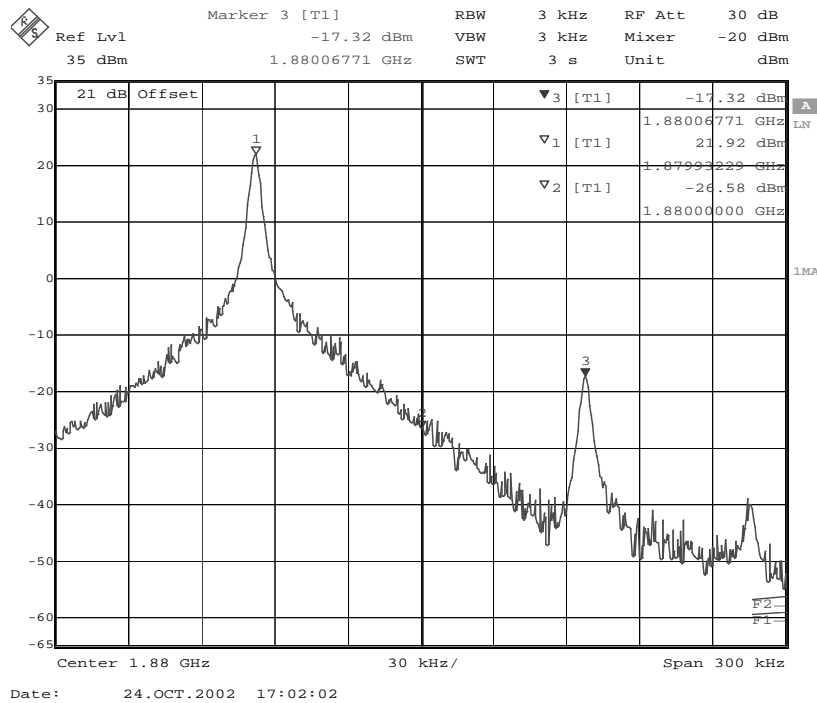

Use the variables 'Amplitude difference' and 'Phase difference' to adjust the +67kHz signal to a minimum level (Marker 3). Tuning can be performed by using the arrow keys on the keyboard. Pushing the sliders by using the mouse is less sensitive however possible.

After tuning to the minimum the level difference between marker 3 and the peak level at marker 1 must exceed 40dB.

The Spectrum Analyzer now shows a plot like this:

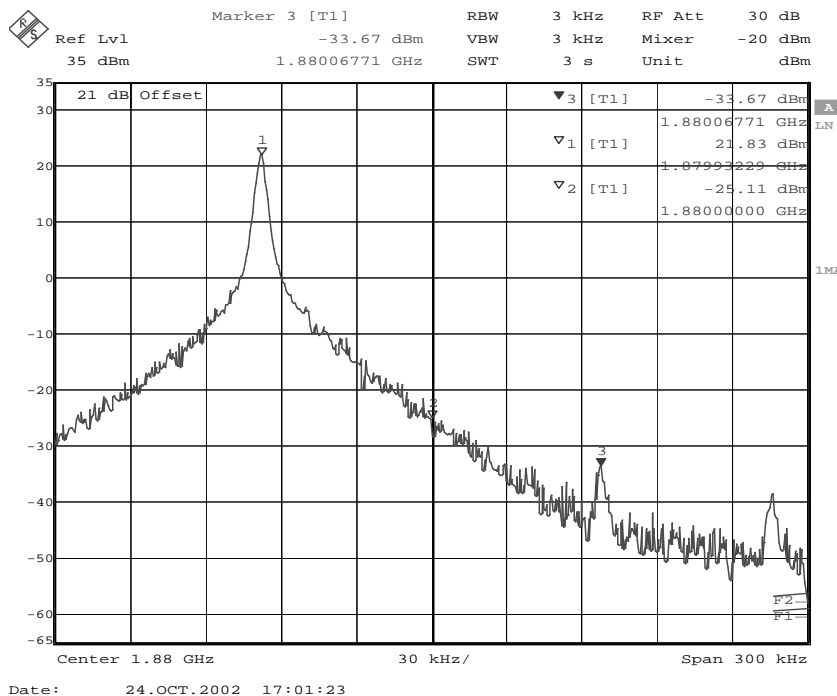

Compare the results in the TX IQ Tuning Window with the limits below:

Value	Typical	Limit min.	Limit max.
TX I DC offset	0.2	-6	6
TX Q DC offset	-0.1	-6	6
Amplitude difference	0	-1	1
Phase difference	89.0	80	100

Select in the TX IQ Tuning Window:

Select  Save to Product

Press Stop

and the values are stored in the phone. The GSM1900 TX IQ Tuning is now finished.

Note: The optimum values for "TX I and Q Offset" and "Amplitude and Phase Difference" vary from phone to phone.

# Customer Care Solutions RH-19 Cellular Phone

## Appendix 7A: FLALI Test Cases

## Appendix A: FLALI Test Cases with Hints for Repair

Step Name	Limits Low	Limits High	Repair Comments
Initialize RF Calibration	-0.5	0.5	If phone is not working, check RFCLK. Can be measured at R426 after power on.
Meas Operation Start Current	3.0	70.0	
Program flash	0.5	1.5	
Program flash PPM	0.5	1.5	
Reset Phone	-0.5	0.5	
Meas Local Mode Current	3.0	70.0	
Check MCU-sw version	0.0	13.0	
Write Product Info	0.5	1.5	
Write_Product_Profile	-0.5	0.5	
Read PCI Version	0.0	2000.0	
Selftest_A	-0.5	0.5	
EMCAL: Calib ADC, VBatt, BSI	26500.0	28500.0	
- Check ADC BATT Voltage Gain	10000.0	11000.0	
- Check ADC VBATT Voltage Offset Scale	2300.0	2900.0	
- Check ADC BSI Calibration Gain	950.0	1100.0	
- Check ADC Voltage offset	-50.0	50.0	
Read BTEMP ADC Value	0.0	60.0	
Calib channel filter_GTR	1.0	63.0	Check RX IQ interface signal.
- Check Channel Select VIPP	8000.0	20000.0	If signal looks ok, then try manual calibration with Phoenix.
- Check Channel Select VQPP	1700.0	4000.0	If calibration fails, change Mjoelner (N601).
Test_LED	2.0	10.0	
Tuning RX GSM9 RSSI	-0.5	0.5	
- Check RX GSM9 Gain A4	76.0	84.0	Check RX900 path (ant.switch Z601+ SAW Z604). Heat SAW solder joints. If RSSI reading is 6 to 10dB too low, then change SAW filter. If no
- Check RX GSM9 Gain A7	98.0	106.0	signal, check RX path up to RX IQ interface. If RX IQ ok then BB check (UEM/UPP). If RX IQ not ok, change Mjoelner (N601).
- Check VCXO_VALUE	128.0	767.0	VCXO/AFC calibration works only, if Rx900 chain is working.
- Check AFC_VALUE	3062.0	3262.0	If calibration does not work at all (fail at "Tuning RX GSM9 RSSI"), check the RFBUS signals.
- Check AFC_Coeff1	0.0	9999.0	Check voltage supplies
- Check AFC_Coeff2	-999.0	0.0	VDDXO@C607, VDDBBB@C636 (2.7V from VR3),
- Check AFC_Coeff3	0.0	1.0	VDDDL@C628 (1.8V from VIO),

Step Name	Limits Low	Limits High	Repair Comments
- Check Calc1	1312.0	4383.0	VBEXT@C615 (1.35V from VREF01).
- Check Calc2	1312.0	4383.0	If voltages are ok, the crystal (B601) and/or Mjoelner (N601) can be exchanged
- Check Calc3	0.0	83.0	
- Check Calc4	0.0	83.0	
Tuning RX GSM18 RSSI	-0.5	0.5	
- Check RX GSM18 Gain A4	72.0	80.0	Check RX1800 path (ant.switch Z601+ SAW Z602). Heat SAW solder joints. If RSSI reading is 6 to 10dB too low, then change SAW filter.
- Check RX GSM18 Gain A7	95.0	103.0	If no signal, check RX path up to RX IQ interface. If RX IQ ok then BB check (UEM/ UPP). If RX IQ not ok, change Mjoelner (N601).
Tuning RX GSM19 RSSI	-0.5	0.5	
- Check RX GSM19 Gain A4	74.0	82.0	Check RX1900 path (ant.switch Z601+ SAW Z603). Heat SAW solder joints. If RSSI reading is 6 to 10dB too low, then change SAW filter.
- Check RX GSM19 Gain A7	94.0	102.0	If no signal, check RX path up to RX IQ interface. If RX IQ ok then BB check (UEM/ UPP). If RX IQ not ok, change Mjoelner (N601).
Meas Operation SNR GSM9 Mid	21.0	27.0	Check RX900 path, start with ant.switch (Z601), then SAW (Z604). If signal is 2 to 4dB too low, change respective comp (ant.switch or SAW).
Meas Operation SNR GSM18 Mid	19.0	25.0	Check RX1800 path start with ant.switch (Z601), then SAW (Z602). If signal is 2 to 4dB too low, change respective comp (ant.switch or SAW).
Meas Operation SNR GSM19 Mid	19.0	25.0	Check RX1900 path, start with ant.switch (Z601), then SAW (Z603). If signal is 2 to 4dB too low, change respective comp (ant.switch or SAW).
Tuning Rx GSM9 Band Filter	-0.5	0.5	
- Check RX GSM9 Band Filter First	-6.0	2.0	If one of the steps 499...507 fails, change RX900 SAW (Z604)
- Check RX GSM9 Band Filter N1	-3.0	1.0	
- Check RX GSM9 Band Filter N2	-3.0	1.0	
- Check RX GSM9 Band Filter N3	-3.0	1.0	
- Check RX GSM9 Band Filter N4	-2.0	1.0	
- Check RX GSM9 Band Filter N5	-3.0	1.0	
- Check RX GSM9 Band Filter N6	-3.0	1.0	
- Check RX GSM9 Band Filter N7	-3.0	1.0	
- Check RX GSM9 Band Filter Last	-9.0	2.0	

Step Name	Limits Low	Limits High	Repair Comments
Tuning Rx GSM18 Band Filter	-0.5	0.5	
- Check RX GSM18 Band Filter First	-6.0	2.0	Check whole TX900 path from modulator output through pre-amplifier, TX SAW, PA, antenna switch according to TX fault finding tree
- Check RX GSM18 Band Filter N1	-3.0	1.0	
- Check RX GSM18 Band Filter N2	-3.0	1.0	
- Check RX GSM18 Band Filter N3	-3.0	1.0	
- Check RX GSM18 Band Filter N4	-2.0	1.0	
- Check RX GSM18 Band Filter N5	-2.0	2.0	
- Check RX GSM18 Band Filter N6	-2.0	2.0	
- Check RX GSM18 Band Filter N7	-2.0	2.0	
- Check RX GSM18 Band Filter Last	-6.0	2.0	
Tuning Rx GSM19 Band Filter	-0.5	0.5	
- Check RX GSM19 Band Filter First	-6.0	2.0	If one of the steps 1047..1055 fails, change RX1900 SAW (Z603)
- Check RX GSM19 Band Filter N1	-3.0	1.0	
- Check RX GSM19 Band Filter N2	-3.0	1.0	
- Check RX GSM19 Band Filter N3	-2.0	2.0	
- Check RX GSM19 Band Filter N4	-2.0	1.0	
- Check RX GSM19 Band Filter N5	-2.0	2.0	
- Check RX GSM19 Band Filter N6	-3.0	1.0	
- Check RX GSM19 Band Filter N7	-3.0	1.0	
- Check RX GSM19 Band Filter Last	-6.0	2.0	
Initialize VSA	-0.5	0.5	
Set VSA Parameters for GSM9 TX Base	-0.5	0.5	
Start TX GSM9 Pow Tunings	-0.5	0.5	
Tuning TX GSM9 Base	-31.0	-20.0	Check whole TX900 path from modulator output through pre-amplifier, TX SAW, PA, antenna switch according to TX fault finding tree
- Check GSM9 TX Base Coef	0.1	0.2	
Set VSA Parameters for GSM9 TX Power	-0.5	0.5	
Meas TX GSM9 PAH Tun Samples	0.0	40.0	
Tuning TX GSM9 PAH	31.5	32.5	
End TX GSM9 Pow Tunings	-0.5	0.5	
Meas GSM9 TX Pow PAH LOW	-0.5	0.5	
- Check GSM9 TX Pow PAH LOW5	31.0	35.0	
- Check GSM9 TX Pow PAH LOW19	2.0	8.0	
Meas GSM9 TX Pow PAH HIGH	-0.5	0.5	
- Check GSM9 TX Pow PAH HIGH5	31.0	35.0	
- Check GSM9 TX Pow PAL HIGH19	2.0	8.0	

Step Name	Limits Low	Limits High	Repair Comments
Set VSA Parameters for GSM9 TX I/Q	-0.5	0.5	
Tuning TX GSM9 I/Q	-0.5	0.5	Check Tx900 path around modulator:
- Check TX GSM9 I DC Offset Tuning	-6.0	6.0	Check Tx IQ signals with Oscilloscope (TXIOUTP, TXIOUTN, TXQOUTP, TXQOUTN).
- Check TX GSM9 Q DC Offset Tuning	-6.0	6.0	Is Tx900 SAW filter (Z701) and Tx900 buffer (V802) ok?
- Check TX GSM9 Amp Diff Tuning	-1.0	1.0	Maybe Mjoelner must be exchanged.
- Check TX GSM9 Phase Diff Tuning	80.0	100.0	
Set VSA Parameters for GSM18 TX Base	-0.5	0.5	
Start TX GSM18 Power Tunings	-0.5	0.5	
Tuning TX GSM18 Base	-31.0	-20.0	Check whole TX1800 path from modulator output through, PA, antenna switch according to TX fault finding tree
- Check GSM18 TX Base Coef	0.1	0.2	
Set VSA Parameters for GSM18 TX Power	-0.5	0.5	
Meas TX GSM18 PAH Tun Samples	0.0	40.0	
Tuning TX GSM18 PAH	28.5	30.0	
End TX GSM18 Pow Tunings	-0.5	0.5	
Meas GSM18 TX Pow PAH LOW	-0.5	0.5	
- Check GSM18 TX Pow PAH LOW0	28.0	32.0	
- Check GSM18 TX Pow PAH LOW15	-3.0	3.0	
Meas GSM18 TX Pow PAH HIGH	-0.5	0.5	
- Check GSM18 TX Pow PAH HIGH0	28.0	32.0	
- Check GSM18 TX Pow PAH HIGH15	-3.0	3.0	
Set VSA Parameters for GSM18 TX I/Q	-0.5	0.5	
Tuning TX GSM18 I/Q	-0.5	0.5	Check Tx1800/1900 path around modulator.
- Check TX GSM18 I DC Offset Tuning	-6.0	6.0	Check Tx IQ signals with Oscilloscope (TXIOUTP, TXIOUTN, TXQOUTP, TXQOUTN).
- Check TX GSM18 Q DC Offset Tuning	-6.0	6.0	Is Tx1800/1900 balun (T701) ok?
- Check TX GSM18 Amp Diff Tuning	-1.0	1.0	Maybe Mjoelner must be exchanged.
- Check TX GSM18 Phase Diff Tuning	80.0	100.0	
Set VSA Parameters for GSM19 TX Base	-0.5	0.5	
Start TX GSM19 Power Tunings	-0.5	0.5	
Tuning TX GSM19 Base	-31.0	-20.0	Very unlikely, if TX1800 is ok.
- Check GSM19 TX Base Coef	0.0	0.2	
Set VSA Parameters for GSM19 TX Power	-0.5	0.5	
Meas TX GSM19 PAH Tun Samples	0.0	40.0	
Tuning TX GSM19 PAH	28.5	30.0	
End TX GSM19 Pow Tunings	-0.5	0.5	
Meas GSM19 TX Pow PAH LOW	-0.5	0.5	

Step Name	Limits Low	Limits High	Repair Comments
- Check GSM19 TX Pow PAH LOW0	28.0	32.0	
- Check GSM19 TX Pow PAH LOW15	-3.0	3.0	
Meas GSM19 TX Pow PAH HIGH	-0.5	0.5	
- Check GSM19 TX Pow PAH HIGH0	28.0	32.0	
- Check GSM19 TX Pow PAH HIGH15	-3.0	3.0	
Set VSA Parameters for GSM19 TX I/Q	-0.5	0.5	
Tuning TX GSM19 I/Q	-0.5	0.5	Check Tx1800/1900 path around modulator.
- Check TX GSM19 I DC Offset Tuning	-6.0	6.0	Check Tx IQ signals with Oscilloscope (TXIOUTP, TXIOUTN, TXQOUTP, TXQOUTN).
- Check TX GSM19 Q DC Offset Tuning	-6.0	6.0	Is Tx1800/1900 balun (T701) ok?
- Check TX GSM19 Amp Diff Tuning	-1.0	1.0	Maybe Mjoelner must be exchanged.
- Check TX GSM19 Phase Diff Tuning	80.0	100.0	
Meas TX GSM9 I/Q MID5	-0.5	0.5	Refer to steps 534-538
- Check TX GSM9 I/Q Fo	-120.0	-35.0	
- Check TX GSM9 I/Q Fo+67k	-120.0	-40.0	
Meas TX GSM18 I/Q MID0	-0.5	0.5	Refer to steps 608 to 612
- Check TX GSM18 I/Q Fo	-120.0	-35.0	
- Check TX GSM18 I/Q Fo+67k	-120.0	-40.0	
Meas TX GSM19 I/Q MID0	-0.5	0.5	Refer to steps 1084 to 1089
- Check TX GSM19 I/Q Fo	-120.0	-35.0	
- Check TX GSM19 I/Q Fo+67k	-120.0	-40.0	
Measure TX On Current 900	0.2	0.3	
Measure TX On Current 1800	0.1	0.3	
Measure TX On Current 1900	0.1	0.2	
Operation IR Test	-0.5	0.5	
Test RTC Battery	1.0	1.0	
Meas Offstate Current	0.0	150.0	



# Customer Care Solutions RH-19 Cellular Phone

## Appendix 7B: FinUI Test Cases

## Appendix B: FinUI Test Cases with Hints for Repair

Test Step Name	Limits			St.Dev	Repair Comments
	Low	High	Average		
Keypad_Start_Test	0	10	0.00	0.00	
Testmode Current Meas	10	200	78.63	11.79	
Read phone SW	0	5000	3.10	0.00	
Read phone HW	0	5000	580.00	0.00	
Initialize RF Calibration	-0.5	0.5	0.00	0.00	
Init TestSet	-0.5	0.5	0.00	0.00	
Set TestSet PCS	-0.5	0.5	0.00	0.00	
SIM Status	0.5	1.5	1.00	0.00	
Read Audio Calibration Values	0	0	1.00	0.00	
Check Charger Voltage	-8600	-8200	-8428.58	20.06	
U Charge Cal Plug	57000	63000	60466.63	444.60	
I Charge Cal THWK	4050	4950	4497.33	95.63	
Check Charger GND Plug	2	3	2.53	0.01	
Check Charger GND THWK	2	3	2.53	0.01	
Apply Bias To Mic	0	0	1.00	0.00	
ACI Test	925	1225	1072.49	15.78	
VOOUT OFF Test	-0.5	0.5	0.05	0.01	
VOOUT ON Test	1	1.6	1.32	0.01	
Keypad_functionality	1	1	1.00	0.00	
Keypad_Result_9	1	1	1.00	0.00	
Keypad_Result_5	1	1	1.00	0.00	
Keypad_Result_End	1	1	1.00	0.00	
Keypad_Result_SoftRight	1	1	1.00	0.00	
Keypad_Result_1	1	1	1.00	0.00	
Keypad_Result_VolUp	1	1	1.00	0.00	
Keypad_Result_VolDown	1	1	1.00	0.00	
Keypad_Result_Power	1	1	1.00	0.00	
Keypad Stuck Test	0	0	0.00	0.00	
Vibra Test (Shock)	250	10000	2124.47	1182.07	
Move robot On the Mic	0	0	1.00	0.00	
Measure audio Bias Voltage	520	720	622.20	4.14	
HYBRID MIC-XEAR (dB) 1,0 kHz	-5	5	0.20	1.53	
Move robot On The Earp	0	0	1.00	0.00	
HYBRID XMIC-EAR (dB) 1,0 kHz	-5	5	-0.45	1.06	
HYBRID Check IHF Ampifier State	-100	-15	-29.94	4.56	
HYBRID XMIC-IHF (dB) 0,8 kHz	-5	5	-1.11	0.92	
HYBRID XMIC-XEAR/IHF (dB) 2,4 kHz	-5	5	0.59	0.93	
Move robot Home	-0.5	0.5	0.00	0.00	
Set Fast Service Ch PCS	-0.5	0.5	0.00	0.00	
Create Call PCS	-0.5	0.5	0.10	0.00	
PCS Measure All Ch=H TxL=0	-0.5	34	0.00	0.00	
Start LCD test	0	0	1.00	0.00	
- Check PCS Burst t=1 H0	-120	-30	-70.57	1.45	
- Check PCS Burst t=2 H0	-70	-6	-18.38	0.28	
- Check PCS Burst t=4 H0	-1	1	-0.47	0.04	

Test Step Name	Limits			St.Dev	Repair Comments
	Low	High	Average		
- Check PCS Burst t=9 H0	-1	1	-0.01	0.02	
- Check PCS Burst t=11 H0	-70	-6	-14.77	0.32	
- Check PCS Burst t=12 H0	-120	-30	-74.86	2.95	
- Check PCS Phase Error Peak H0	0	20	8.31	1.75	Check shielding and antenna connection.
- Check PCS Phase Error Rms H0	0	5	2.68	0.25	Check the following capacitors if soldered properly: C701, C702, C703 (around antenna switch),
- Check PCS Freq Error H0	-180	180	19.39	13.23	C610, C741 (around VCO), C626 (around Mjølner), C709, C710, C711, C712 (loop filter).
- Check PCS TX Swit Spec 400 kHz H0	-90	-22	-30.43	0.97	
- Check PCS TX Swit Spec -400 kHz H0	-90	-22	-31.08	1.00	
-Check PCS TX Mod Spec 400kHz H0	0	15	4.39	0.95	
-Check PCS TX Mod Spec -400kHz H0	0	15	5.35	0.91	
- Check PCS BER -102 H	0	2	0.05	0.03	Check antenna connection.
- Check PCS SACCH H0	4	12	8.72	0.47	Check RX1900 path (antenna switch, SAW filter, RX IQ interface)
- Check PCS TX Power H0	26.5	33	30.42	0.40	Check shielding and antenna connection.
Meas PCS TX Power H1	25.5	30.5	28.74	0.35	
Contrast Tuning	-10	10	-5.75	2.07	
Check Contrast Value	0.25	0.5	0.33	0.04	
- Check PCS TX Power Linearity H0-H1	0.5	3.5	1.68	0.14	
Start Display Illumination Test	0	0	1.00	0.00	
Meas PVT TX Power H15	-5	5	1.13	0.38	Check shielding and antenna connection.
- Check PCS Burst t=1 H15	-120	-20	-41.55	1.23	
- Check PCS Burst t=2 H15	-70	-1	-22.08	0.87	
- Check PCS Burst t=4 H15	-1	1	-0.32	0.05	
- Check PCS Burst t=9 H15	-1	1	0.02	0.02	
- Check PCS Burst t=11 H15	-70	-1	-15.09	0.66	
- Check PCS Burst t=12 H15	-120	-20	-60.68	2.52	
Check Display Illumination	0	0	1.00	0.00	
PCS Measure All Ch=L TxL=0	-0.5	34	0.00	0.00	
Start Keypad Illumination Test	0	0	1.00	0.00	
- Check PCS Burst t=1 L0	-120	-30	-73.52	1.79	
- Check PCS Burst t=2 L0	-70	-6	-18.50	0.28	
- Check PCS Burst t=4 L0	-1	1	-0.46	0.04	
- Check PCS Burst t=9 L0	-1	1	-0.01	0.02	
- Check PCS Burst t=11 L0	-70	-6	-14.89	0.32	
- Check PCS Burst t=12 L0	-120	-30	-76.64	3.00	
- Check PCS Phase Error Peak L0	0	20	7.93	1.13	Check shielding and antenna connection.
- Check PCS Phase Error Rms L0	0	5	2.63	0.23	Check the following capacitors if soldered properly: C701, C702, C703 (around antenna switch),
- Check PCS Freq Error L0	-180	180	13.83	12.89	C610, C741 (around VCO), C626 (around Mjølner), C709, C710, C711, C712 (loop filter).
- Check PCS TX Swit Spec 400 kHz L0	-90	-22	-31.32	0.91	
- Check PCS TX Swit Spec -400 kHz L0	-90	-22	-31.15	0.94	
-Check PCS TX Mod Spec 400kHz L0	0	15	5.25	0.77	

Test Step Name	Limits			St.Dev	Repair Comments
	Low	High	Average		
-Check PCS TX Mod Spec -400kHz L0	0	15	5.45	0.73	
- Check PCS BER -102 L0	0	2	0.06	0.03	Check antenna connection.
- Check PCS SACCH L0	4	12	8.99	0.31	Check RX1900 path (antenna switch, SAW filter, RX IQ interface)
- Check PCS TX Power L0	26.5	33	30.03	0.36	Check shielding and antenna connection.
Check Keypad Illumination	0	0	1.00	0.00	
Meas PCS TX Power L1	25.5	30.5	28.37	0.27	Check shielding and antenna connection.
- Check PCS TX Power Linearity L0-L1	0.5	3.5	1.66	0.15	
Meas PVT TX Power L15	-5	5	0.42	0.31	
- Check PCS Burst t=1 L15	-120	-20	-44.29	1.42	
- Check PCS Burst t=2 L15	-70	-1	-24.17	0.91	
- Check PCS Burst t=4 L15	-1	1	-0.31	0.05	
- Check PCS Burst t=9 L15	-1	1	0.02	0.02	
- Check PCS Burst t=11 L15	-70	-1	-16.37	0.75	
- Check PCS Burst t=12 L15	-120	-20	-62.04	2.67	
Operation End display keypad Test	0	0	1.00	0.00	
End Call PCS	-0.5	0.5	0.00	0.00	
Set TestSet GSM	-0.5	0.5	0.00	0.00	
Set Fast Service Ch GSM	-0.5	0.5	0.00	0.00	
Create Call GSM	-0.5	0.5	0.10	0.00	
GSM Measure All Ch=H TxL=5	0	35	0.00	0.00	
- Check GSM Freq Error H5	-90	90	10.69	7.32	Check shielding and antenna connection.
- Check GSM Phase Error Peak H5	0	20	6.05	0.98	Check the following capacitors if soldered properly: C701, C702, C703 (around antenna switch),
- Check GSM Phase Error Rms H5	0	5	1.79	0.12	C610, C741 (around VCO), C626 (around Mjølner), C709, C710, C711, C712 (loop filter).
- Check GSM TX Spectrum 400 kHz H5	-60	-19	-30.37	0.82	
- Check GSM TX Swit Spec -400 kHz H5	-60	-19	-30.96	0.79	
-Check GSM TX Mod Spec 400kHz H5	-100	-60	-65.00	0.66	
-Check GSM TX Mod Spec -400kHz H5	-100	-60	-64.30	0.66	
- Check GSM BER -102 H5	0	2	0.01	0.01	Check antenna connection.
- Check GSM SACCH H5	4	12	10.41	0.50	Check RX900 path (antenna switch, SAW filter, RX IQ interface)
- Check GSM TX Power H5	30	35.5	32.08	0.38	Check shielding and antenna connection
Meas GSM9 Call Mode Current H5	120	360	266.63	35.71	
Meas GSM TX Power H6	28.5	33.5	30.31	0.38	Check shielding and antenna connection
- Check GSM TX Power Linearity H5-H6	0.5	3.5	1.77	0.03	
Meas GSM PVT TX Power H19	0	10	4.79	0.47	
- Check GSM Burst t=1 H19	-120	-22	-52.88	1.76	
- Check GSM Burst t=2 H19	-70	-1	-25.97	0.88	
- Check GSM Burst t=4 H19	-1	1	-0.48	0.06	
- Check GSM Burst t=9 H19	-1	1	-0.01	0.02	
- Check GSM Burst t=11 H19	-70	-1	-13.66	1.57	
- Check GSM Burst t=12 H19	-120	-22	-68.50	1.84	
GSM Measure All Ch=L TxL=5	-0.5	35	0.00	0.00	
- Check GSM Burst t=1 L5	-120	-30	-80.09	2.19	

Test Step Name	Limits			St.Dev	Repair Comments
	Low	High	Average		
- Check GSM Burst t=2 L5	-70	-6	-16.24	0.26	
- Check GSM Burst t=4 L5	-1	1	-0.71	0.05	
- Check GSM Burst t=9 L5	-1	1	-0.12	0.03	
- Check GSM Burst t=11 L5	-70	-6	-11.88	0.23	
- Check GSM Burst t=12 L5	-120	-30	-82.79	1.77	
- Check GSM TX Spectrum 400 kHz L5	-60	-19	-28.97	0.80	
- Check GSM TX Swit Spec -400 kHz L5	-60	-19	-30.17	0.77	
-Check GSM TX Mod Spec 400kHz L5	-100	-60	-65.30	0.57	
-Check GSM TX Mod Spec -400kHz L5	-100	-60	-64.45	0.54	
- Check GSM Phase Error Peak L5	0	20	6.11	1.95	Check shielding and antenna connection.
- Check GSM Phase Error Rms L5	0	5	1.80	0.16	Check the following capacitors if soldered properly: C701, C702, C703 (around antenna switch),
- Check GSM Freq Error L5	-90	90	8.33	7.29	C610, C741 (around VCO), C626 (around Mjølner), C709, C710, C711, C712 (loop filter).
- Check GSM BER -102 L5	0	2	0.03	0.02	Check antenna connection.
- Check GSM SACCH L5	4	12	9.01	0.60	Check RX900 path (antenna switch, SAW filter, RX IQ interface)
- Check GSM TX Power L5	30	35.5	32.90	0.28	Check shielding and antenna connection
Meas GSM TX Power L6	28.5	33.5	31.36	0.27	Check shielding and antenna connection
- Check GSM TX Power Linearity L5-L6	0.5	3.5	1.55	0.11	
Meas GSM PVT TX Power L19	0	10	5.75	0.37	
- Check GSM Burst t=1 L19	-120	-22	-56.70	1.95	
- Check GSM Burst t=2 L19	-70	-1	-27.92	0.92	
- Check GSM Burst t=4 L19	-1	1	-0.43	0.06	
- Check GSM Burst t=9 L19	-1	1	-0.01	0.02	
- Check GSM Burst t=11 L19	-70	-1	-15.54	1.88	
- Check GSM Burst t=12 L19	-120	-22	-69.77	2.01	
Handover GSM-DCS	-0.5	0.5	0.00	0.00	
DCS Measure All Ch=H TxL=0	-0.5	34	0.00	0.00	
- Check DCS Burst t=1 H0	-120	-30	-76.34	2.11	
- Check DCS Burst t=2 H0	-70	-6	-18.66	0.28	
- Check DCS Burst t=4 H0	-1	1	-0.46	0.04	
- Check DCS Burst t=9 H0	-1	1	-0.01	0.02	
- Check DCS Burst t=11 H0	-70	-6	-14.93	0.32	
- Check DCS Burst t=12 H0	-120	-30	-76.16	3.32	
- Check DCS Phase Error Peak H0	0	20	8.07	1.88	Check shielding and antenna connection.
- Check DCS Phase Error Rms H0	0	5	2.57	0.26	Check the following capacitors if soldered properly: C701, C702, C703 (around antenna switch),
- Check DCS Freq Error H0	-180	180	9.96	13.50	C610, C741 (around VCO), C626 (around Mjølner), C709, C710, C711, C712 (loop filter).
- Check DCS BER -102 H0	0	2	0.05	0.03	Check antenna connection.
- Check DCS SACCH H0	4	12	8.82	0.43	Check RX1800 path (antenna switch, SAW filter, RX IQ interface)
- Check DCS TX Power H0	27	33	29.63	0.40	Check shielding and antenna connection
- Check DCS TX Swit Spec 400 kHz H0	-60	-22	-32.47	0.88	

Test Step Name	Limits			St.Dev	Repair Comments
	Low	High	Average		
- Check DCS TX Swit Spec -400 kHz H0	-60	-22	-32.41	0.91	
-Check DCS TX Mod Spec 400kHz H0	0	15	6.75	0.66	
-Check DCS TX Mod Spec -400kHz H0	0	15	6.97	0.63	
Meas DCS TX Power H1	25.5	30.5	27.75	0.37	Check shielding and antenna connection
- Check DCS TX Power Linearity H0-H1	0.5	3.5	1.88	0.10	
Meas DCS PVT TX Power H15	-5	5	-0.30	0.42	
- Check DCS Burst t=1 H15	-120	-20	-47.23	1.77	
- Check DCS Burst t=2 H15	-70	-1	-23.66	1.26	
- Check DCS Burst t=4 H15	-1	1	-0.28	0.06	
- Check DCS Burst t=9 H15	-1	1	0.04	0.03	
- Check DCS Burst t=11 H15	-70	-1	-15.88	1.07	
- Check DCS Burst t=12 H15	-120	-20	-62.06	3.07	
DCS Measure All Ch=L TxL=0	-0.5	34	0.00	0.00	
- Check DCS Burst t=1 L0	-120	-30	-78.55	2.25	
- Check DCS Burst t=2 L0	-70	-6	-18.62	0.27	
- Check DCS Burst t=4 L0	-1	1	-0.46	0.04	
- Check DCS Burst t=9 L0	-1	1	-0.01	0.02	
- Check DCS Burst t=11 L0	-70	-6	-14.98	0.32	
- Check DCS Burst t=12 L0	-120	-30	-77.09	3.35	
- Check DCS Phase Error Peak L0	0	20	8.18	1.83	Check shielding and antenna connection.
- Check DCS Phase Error Rms L0	0	5	2.63	0.27	Check the following capacitors if soldered properly: C701, C702, C703 (around antenna switch),
- Check DCS Freq Error L0	-180	180	7.83	12.32	C610, C741 (around VCO), C626 (around Mjølner), C709, C710, C711, C712 (loop filter).
- Check DCS TX Spectrum 400 kHz L0	-60	-22	-31.73	1.01	
- Check DCS TX Swit Spec -400 kHz L0	-60	-22	-31.90	1.03	
-Check DCS TX Mod Spec 400kHz L0	0	15	5.98	0.89	
-Check DCS TX Mod Spec -400kHz L0	0	15	6.49	0.87	
- Check DCS BER -102 L0	0	2	0.04	0.02	Check antenna connection.
- Check DCS SACCH L0	4	12	9.57	0.50	Check RX1800 path (antenna switch, SAW filter, RX IQ interface)
- Check DCS TX Power L0	27	33	30.41	0.64	Check shielding and antenna connection
Meas DCS TX Power L1	25.5	30.5	28.50	0.64	Check shielding and antenna connection
- Check DCS TX Power Linearity L0-L1	0.5	3.5	1.91	0.08	
Meas DCS PVT TX Power L15	-5	5	0.57	0.68	
- Check DCS Burst t=1 L15	-120	-20	-50.03	2.11	
- Check DCS Burst t=2 L15	-70	-1	-23.94	1.53	
- Check DCS Burst t=4 L15	-1	1	-0.24	0.05	
- Check DCS Burst t=9 L15	-1	1	0.04	0.03	
- Check DCS Burst t=11 L15	-70	-1	-14.68	1.17	
- Check DCS Burst t=12 L15	-120	-20	-62.30	3.43	
End Call	-0.5	0.5	0.00	0.00	

Appendix 7C: Component Placement with Test Points & Detailed Description

Table of Contents

	Page No
Table of Contents .....	7C-1
Receiver Test Points (1 of 1) .....	7C-2
Synthesizer Test Points (1 of 1) .....	7C-3
Transmitter Test Points (1 of 3) .....	7C-4
Transmitter Test Points (2 of 3) .....	7C-5
Transmitter Test Points (3 of 3) .....	7C-6

Receiver Test Points

Testpoint	Antenna Feed		
Band	GSM900	GSM1800	GSM1900
Active Unit	RX		
Operation Mode	Continuous		
RX/TX Channel	37	700	661
AGC	14		
Input Power	-60dBm	-60dBm	-60dBm
Input Frequency	942.46771MHz	1842.86771MHz	1960.06771MHz
Probed Power (e.g. measured with resistive probe)	Pref (dBm) typ. -- 70dBm	Pref (dBm) typ. -- 70dBm	Pref (dBm) typ. -- 72dBm

Testpoint	RX DCS
Band	GSM1800
Active Unit	RX
Operation Mode	Continuous
RX/TX Channel	700
AGC	14
Input Power	-60dBm
Input Frequency	1842.86771MHz
Probed Power	Pref - 1.5dB

Testpoint	RX GSM
Band	GSM900
Active Unit	RX
Operation Mode	Continuous
RX/TX Channel	37
AGC	14
Input Power	-60dBm
Input Frequency	942.46771MHz
Probed Power	Pref - 1.0dB

Testpoint	RX PCS
Band	GSM1900
Active Unit	RX
Operation Mode	Continuous
RX/TX Channel	661
AGC	14
Input Power	-60dBm
Input Frequency	1960.06771MHz
Probed Power	Pref - 1.5dB

Testpoint	VR6
Band	GSM900
Active Unit	RX
Operation Mode	Continuous or Burst
RX/TX Channel	37
DC Level	-2.7 V

Testpoint	VR4
Band	GSM900
Active Unit	RX
Operation Mode	Continuous or Burst
RX/TX Channel	37
DC Level	-2.7 V

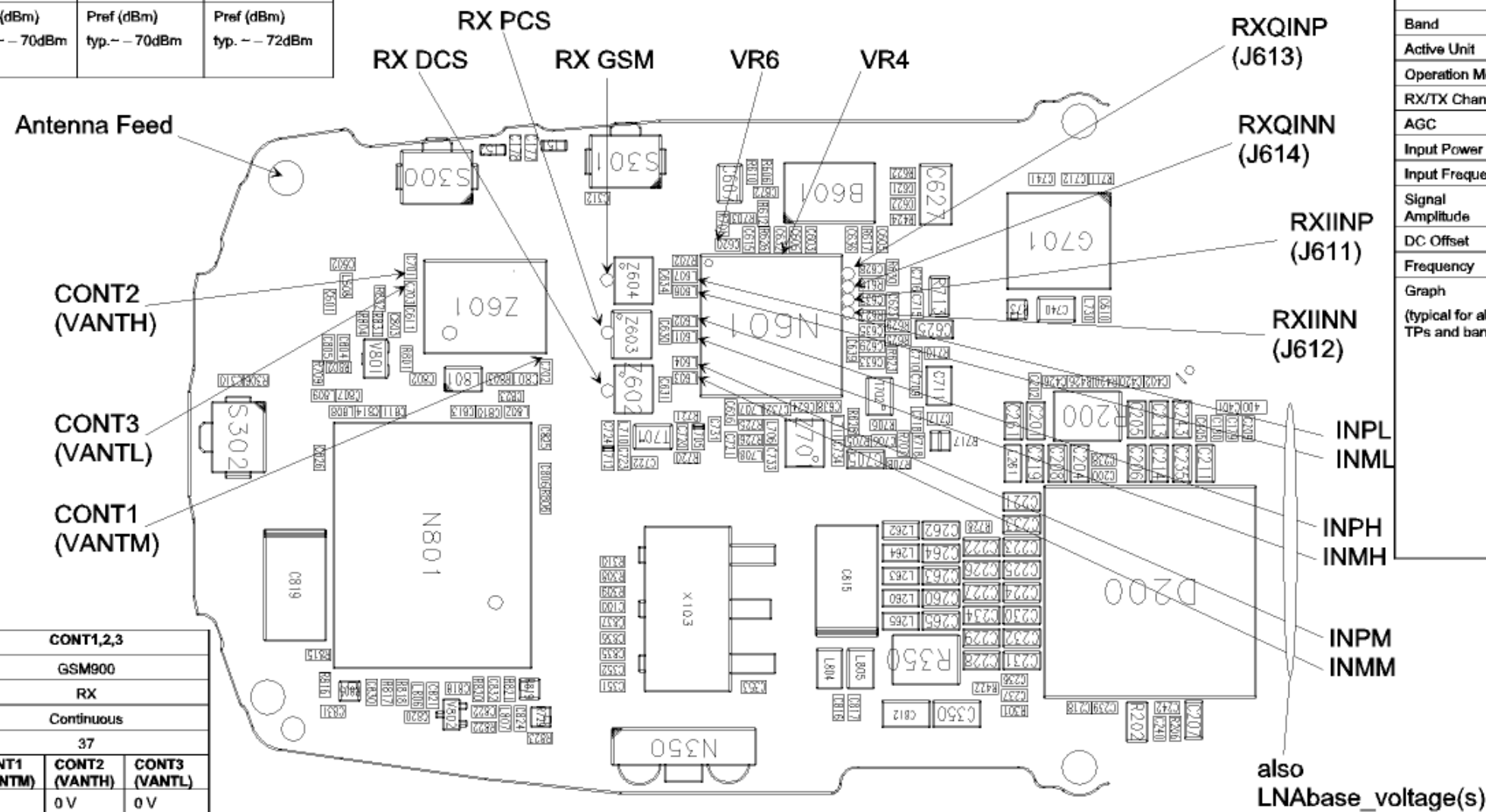

Testpoints	RXQINP (J613) RXQINN (J614) RXIINP (J611) RXIINN (J612)
Band	GSM900 or GSM1800 or GSM1900
Active Unit	RX
Operation Mode	Continuous
RX/TX Channel	37 or 700 or 661
AGC	14
Input Power	-80dBm
Input Frequency	942.46771, 1842.86771 or 1960.06771MHz
Signal Amplitude	1.2Vpp
DC Offset	1.36Vdc
Frequency	67kHz
Graph (typical for all TPs and bands)	

Testpoint	CONT1,2,3		
Band	GSM900		
Active Unit	RX		
Operation Mode	Continuous		
RX/TX Channel	37		
Testpoints	CONT1 (VAN TM)	CONT2 (VAN TH)	CONT3 (VAN TL)
DC Level	0 V	0 V	0 V

Testpoint	CONT1,2,3		
Band	GSM1800		
Active Unit	RX		
Operation Mode	Continuous		
RX/TX Channel	700		
Testpoints	CONT1 (VAN TM)	CONT2 (VAN TH)	CONT3 (VAN TL)
DC Level	0 V	0 V	0 V

Testpoint	CONT1,2,3		
Band	GSM1900		
Active Unit	RX		
Operation Mode	Continuous		
RX/TX Channel	661		
Testpoints	CONT1 (VAN TM)	CONT2 (VAN TH)	CONT3 (VAN TL)
DC Level	0 V	2.7 V	0 V

Testpoints	INPM INMM
Band	GSM1800
Active Unit	RX
Operation Mode	Continuous
RX/TX Channel	700
AGC	14
Input Power	-60dBm
Input Frequency	1960.06771MHz
Probed Power	Pref - 4.0dB
DC Level (=LNAbase_voltage)	0.8V

Testpoints	INPH INMH
Band	GSM1900
Active Unit	RX
Operation Mode	Continuous
RX/TX Channel	661
AGC	14
Input Power	-60dBm
Input Frequency	1842.86771MHz
Probed Power	Pref - 4.0dB
DC Level (=LNAbase_voltage)	0.8V

Testpoints	INPL INML
Band	GSM900
Active Unit	RX
Operation Mode	Continuous
RX/TX Channel	37
AGC	14
Input Power	-60dBm
Input Frequency	942.46771MHz
Probed Power	Pref - 4.0dB
DC Level (=LNAbase_voltage)	0.8V



Synthesizer Test Points

Testpoint	VR3
Band	GSM900
Active Unit	RX
Operation Mode	Continuous or Burst
RX/TX Channel	37
DC Level	2.8V

Testpoint	Utune		
Band	GSM1800	GSM1900	GSM1900
Active Unit	TX	TX	RX
Operation Mode	Continuous		
RX/TX Channel	512	512	810
Frequency	3420.4MHz	3700.4MHz	3979.6MHz
DC Level	~ 1.1V	~ 2.3V	~ 3.5V
Note	Take care to select the highest PCL 15 if activating TX Continuous mode, otherwise the power amplifier will be destroyed.		

Testpoint	VCOout		
	Band	GSM1800	GSM1900
Active Unit	TX	TX	RX
Operation Mode	Continuous		
RX/TX Channel	512	512	810
Frequency	3420.4MHz	3700.4MHz	3979.6MHz
RF Pout (spec. range = -1...+5dBm)	~ 4.5dBm	~ 4.8dBm	~ 1.0dBm
Notes	Measured using a power meter or a spectrum analyzer in line with 470Ohm, which adds an attenuation of 20.3dB. Take care to select the highest PCL 15 if activating TX Continuous mode, otherwise the power amplifier will be destroyed.		

Testpoint	VREF01
Band	GSM900
Active Unit	RX
Operation Mode	Continuous or Burst
RX/TX Channel	37
DC Level	1.35V

Testpoint	VR7
Band	GSM900
Active Unit	RX
Operation Mode	Continuous or Burst
RX/TX Channel	37
DC Level	2.8V

Testpoint	VIO
Band	GSM900
Active Unit	RX
Operation Mode	Continuous or Burst
RX/TX Channel	37
DC Level	1.8V

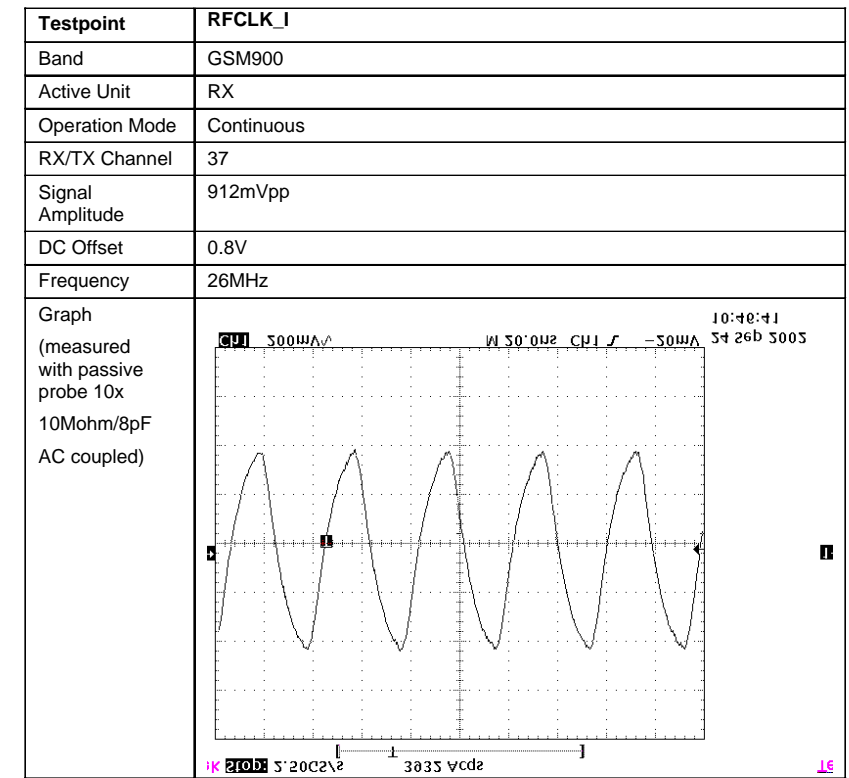
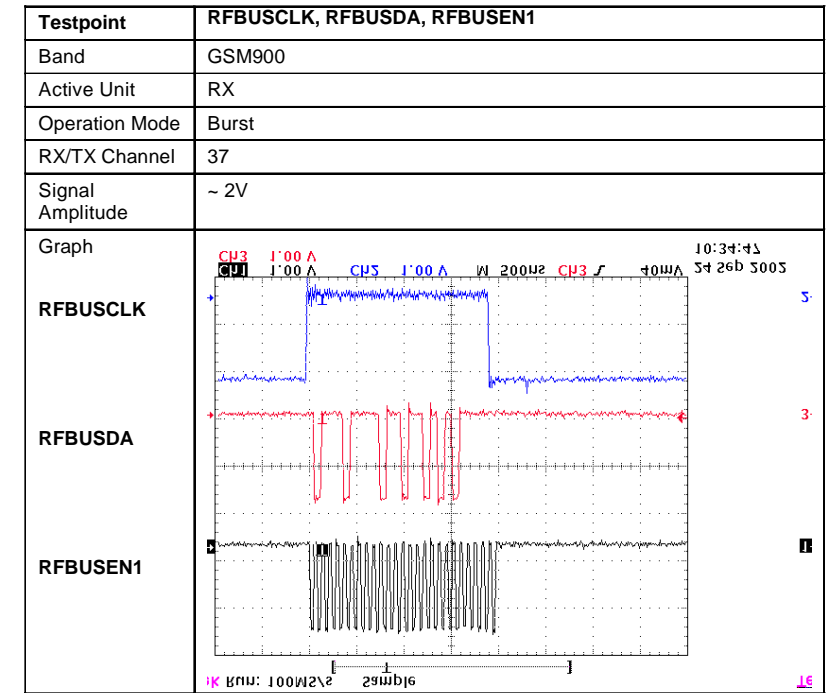
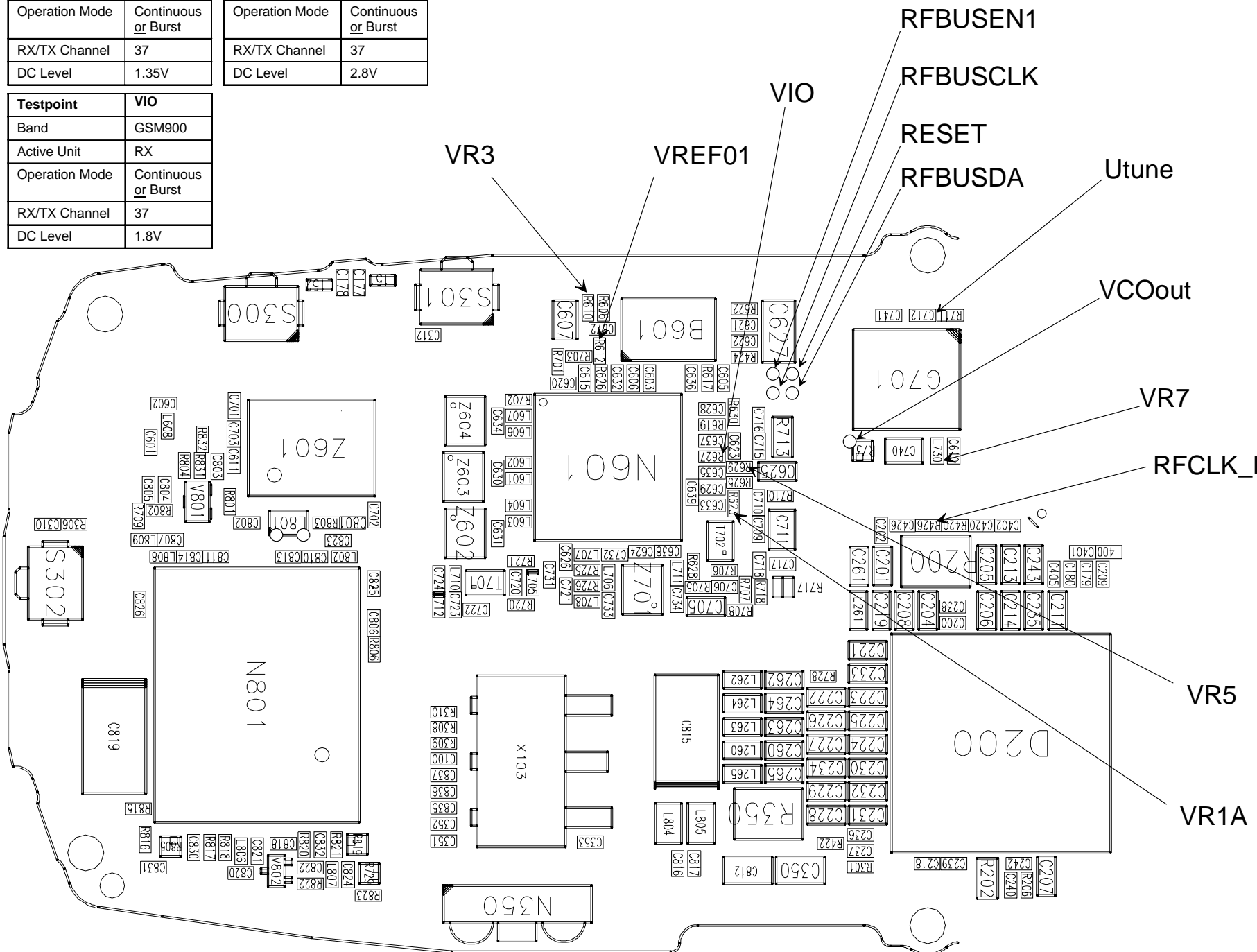

Testpoint	VR5
Band	GSM900
Active Unit	RX
Operation Mode	Continuous or Burst
RX/TX Channel	37
DC Level	2.78V

Testpoint	VR1A
Band	GSM900
Active Unit	RX
Operation Mode	Continuous or Burst
RX/TX Channel	37
DC Level	4.76V

Transmitter Test Points (1 of 3)

Testpoint	CONT1,2,3																						
Band	GSM900/1800/1900																						
Active Unit	TX																						
Operation Mode	Burst																						
DC Level	0 V	0 V	0 V																				
Graph	<p><b>Antenna Switch Control Signals in TX Mode</b></p> <p>Upper curve: TXP Signal (used as trigger signal)</p> <p>Lower curve: see table</p> <table border="1"> <thead> <tr> <th>Z601</th> <th>Pin 8</th> <th>Pin10</th> <th>Pin 14</th> </tr> </thead> <tbody> <tr> <td>TX Mode</td> <td>Cont1</td> <td>Cont2</td> <td>Cont3</td> </tr> <tr> <td>GSM900</td> <td>0</td> <td>0</td> <td>2.7V</td> </tr> <tr> <td>GSM1800</td> <td>2.7V</td> <td>2.7V</td> <td>0</td> </tr> <tr> <td>GSM1900</td> <td>2.7V</td> <td>2.7V</td> <td>0</td> </tr> </tbody> </table>			Z601	Pin 8	Pin10	Pin 14	TX Mode	Cont1	Cont2	Cont3	GSM900	0	0	2.7V	GSM1800	2.7V	2.7V	0	GSM1900	2.7V	2.7V	0
Z601	Pin 8	Pin10	Pin 14																				
TX Mode	Cont1	Cont2	Cont3																				
GSM900	0	0	2.7V																				
GSM1800	2.7V	2.7V	0																				
GSM1900	2.7V	2.7V	0																				

Testpoints	TXIOUTP (R713/1) TXIOUTN (R713/3) TXQOUTP (R713/7) TXQOUTN (R713/5))
Band	GSM900 or GSM1800 or GSM1900
Active Unit	TX
Operation Mode	Burst
RX/TX Channel	37 or 700 or 661
Tx Data Type	Random
Tx Power Level	It doesn't matter
Signal Amplitude	500mVpp
DC Offset	1.0Vdc
Graph	<p><b>IQ Signal: TXQOUTP EGSM900</b></p> <p>Upper curve: TXP Signal (used as trigger signal)</p> <p>Lower curve: TXQOUTP measured at R731, pin 7</p> <p>Marker value shows DC-Offset (left marker)</p>

Testpoint	VR5
Band	GSM900
Active Unit	TX
Operation Mode	Burst
RX/TX Channel	37
DC Level	2.78V

Testpoint	VR3
Band	GSM900
Active Unit	TX
Operation Mode	Burst
RX/TX Channel	37
DC Level	2.8V

Testpoint	VR2 (C721)
Band	GSM900/1800/1900
Active Unit	TX
Operation Mode	Burst
RX/TX Channel	37
DC Level	2.8V

Testpoint	VREF01
Band	GSM900
Active Unit	TX
Operation Mode	Burst
RX/TX Channel	37
DC Level	1.35V

Testpoints	TXC (J702)	TXC (J702)
Band	GSM900	GSM1800 or GSM1900
Active Unit	TX	TX
Operation Mode	Burst	Burst
DC Offset	0Vdc	0Vdc

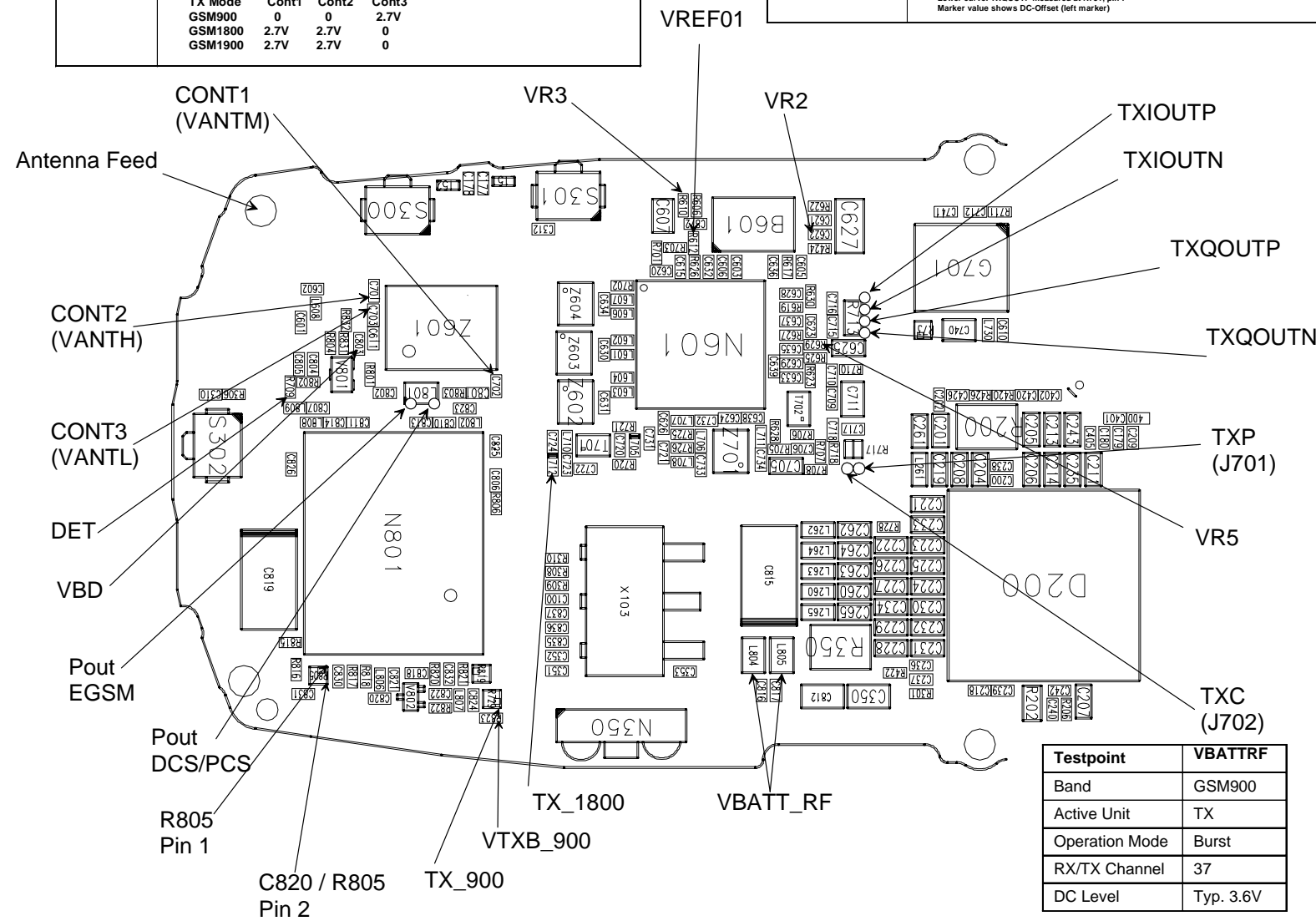
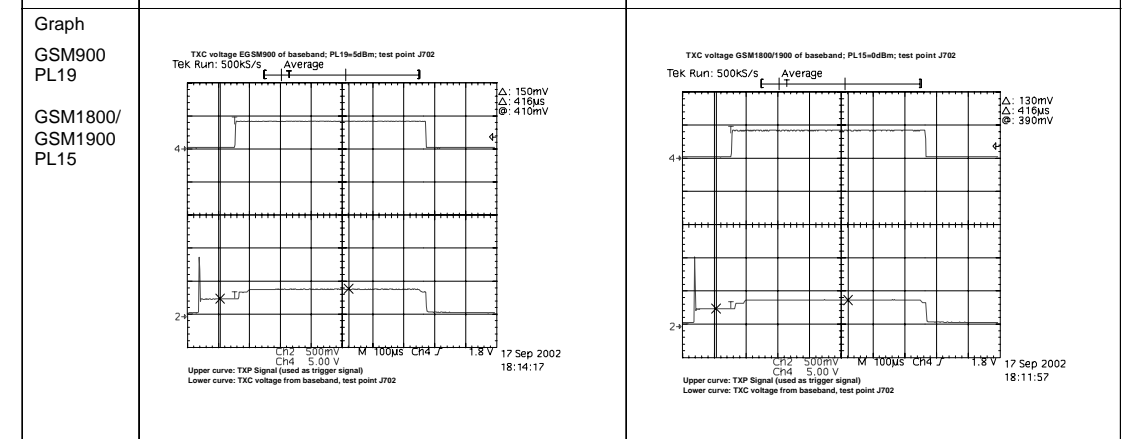
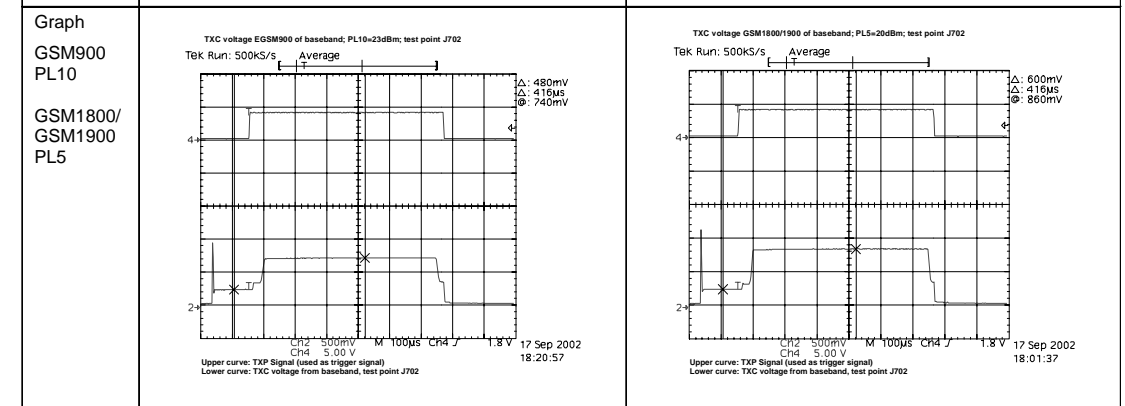
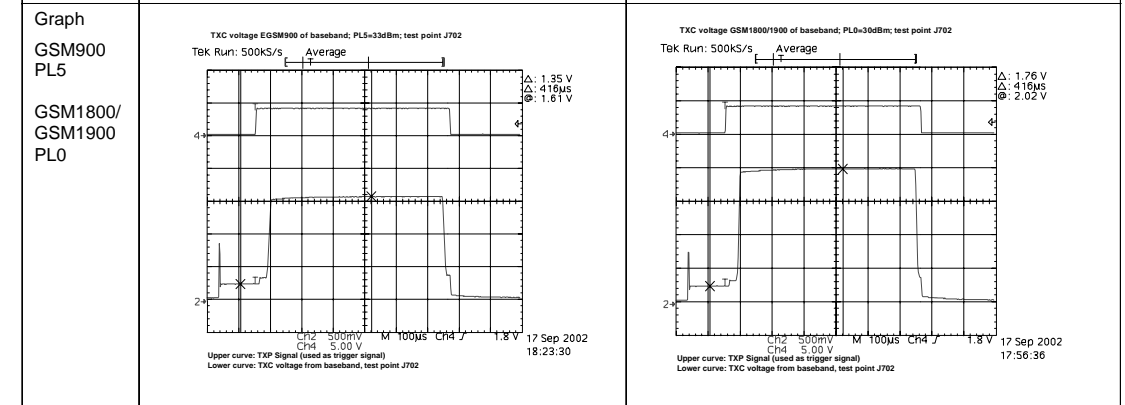

Testpoint	VBATTRF
Band	GSM900
Active Unit	TX
Operation Mode	Burst
RX/TX Channel	37
DC Level	Typ. 3.6V

Transmitter Test Points (2 of 3)

Testpoint	Antenna Feed	Testpoint	Antenna Feed
Band	GSM900	Band	GSM1800/1900
Active Unit	TX	Active Unit	TX
Operation Mode	Burst	Operation Mode	Burst
RX/TX Channel	37	RX/TX Channel	700/661
Tx Power Level	5	Tx Power Level	0
Power	Typ. +32.5dBm	Power	Typ. +30dBm

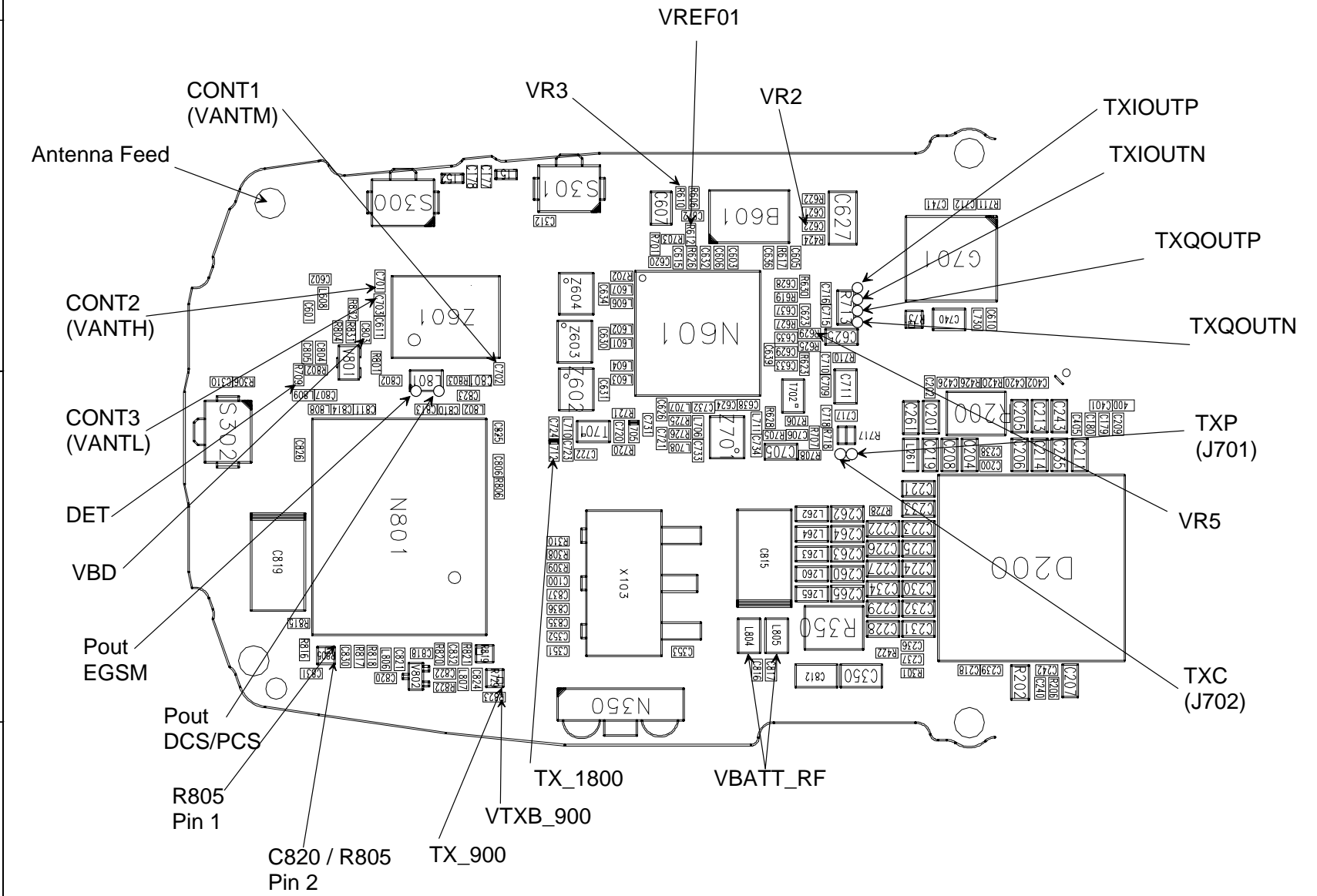

Testpoint	Pout EGSM
Band	GSM900
Active Unit	TX
Operation Mode	Burst
RX/TX Channel	37
Tx Power Level	5
Power	Typ. +34dBm

Testpoint	Pout DCS/PCS
Band	GSM1800/1900
Active Unit	TX
Operation Mode	Burst
RX/TX Channel	700/661
Tx Power Level	0
Power	Typ. +32dBm

Testpoint	R805 Pin 1
Band	GSM900
Active Unit	TX
Operation Mode	Burst
RX/TX Channel	37
Probed Power	Pref 0dBm

Testpoint	C820 / R805 (Pin 2)
Band	GSM900
Active Unit	TX
Operation Mode	Burst
RX/TX Channel	37
Probed Power	Pref +6dBm

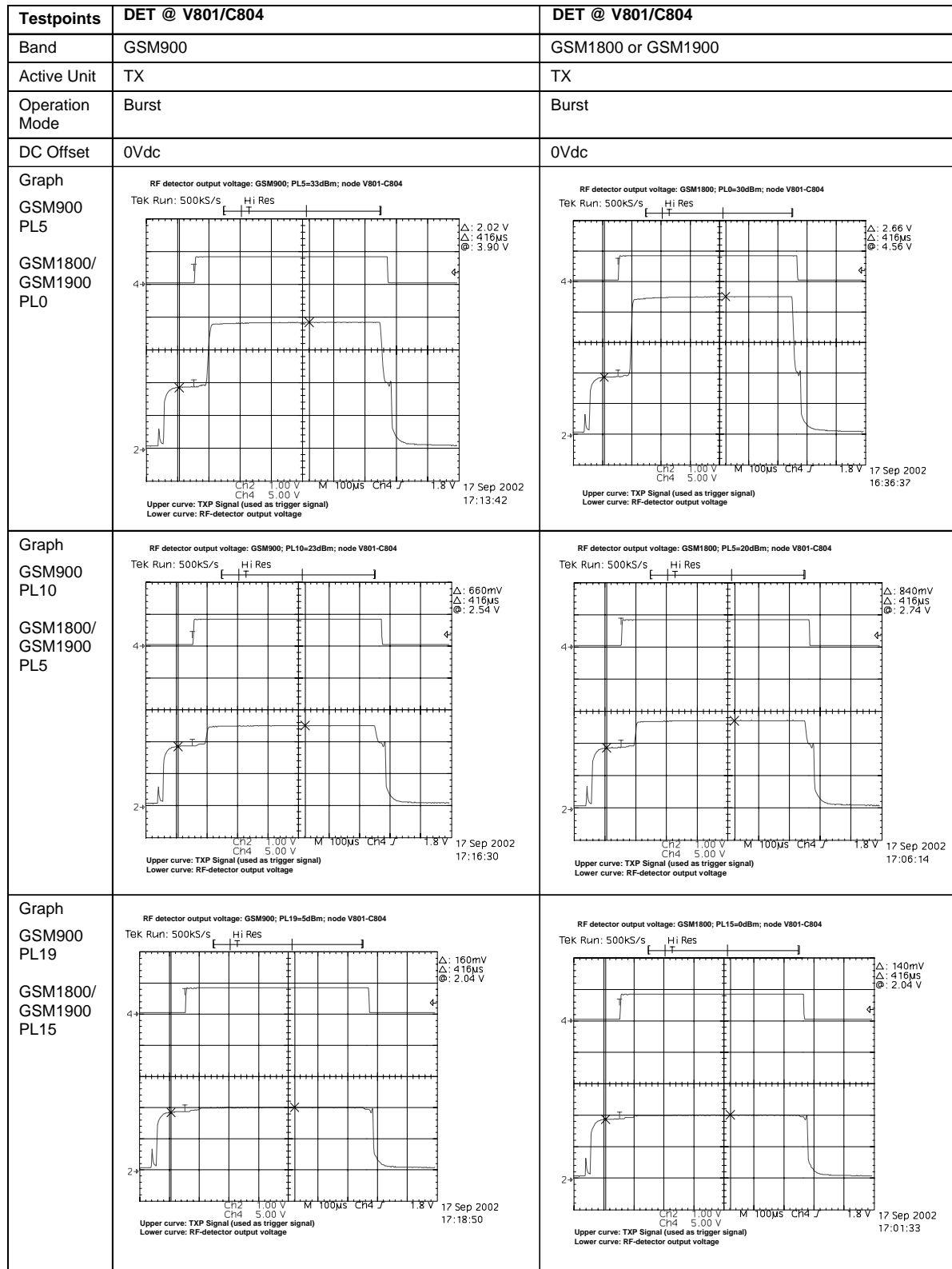

Transmitter Test Points (3 of 3)

Testpoints	N801 / Pin 10 (VPCTRL EGSM900)	N801 / Pin 11 (VPCTRL GSM1800/1900)
Band	GSM900	GSM1800 or GSM1900
Active Unit	TX	TX
Operation Mode	Burst	Burst
DC Offset	0Vdc	0Vdc
Graph	<p>Vpctrl EGSM900 of PA; PL5=33dBm; N801 Pin 10</p> <p>Upper curve: TXP Signal (used as trigger signal) Lower curve: Vpctrl voltage of PA, pin 10</p>	<p>Vpctrl GSM1800/1900 of PA; PL5=33dBm; N801 Pin 11</p> <p>Upper curve: TXP Signal (used as trigger signal) Lower curve: Vpctrl voltage of PA, pin 11</p>
Graph	<p>Vpctrl EGSM900 of PA; PL10=23dBm; N801 Pin 10</p> <p>Upper curve: TXP Signal (used as trigger signal) Lower curve: Vpctrl voltage of PA, pin 10</p>	<p>Vpctrl GSM1800/1900 of PA; PL5=20dBm; N801 Pin 11</p> <p>Upper curve: TXP Signal (used as trigger signal) Lower curve: Vpctrl voltage of PA, pin 11</p>
Graph	<p>Vpctrl EGSM900 of PA; PL19=5dBm; N801 Pin 10</p> <p>Upper curve: TXP Signal (used as trigger signal) Lower curve: Vpctrl voltage of PA, pin 10</p>	<p>Vpctrl GSM1800/1900 of PA; PL15=0dBm; N801 Pin 11</p> <p>Upper curve: TXP Signal (used as trigger signal) Lower curve: Vpctrl voltage of PA, pin 11</p>

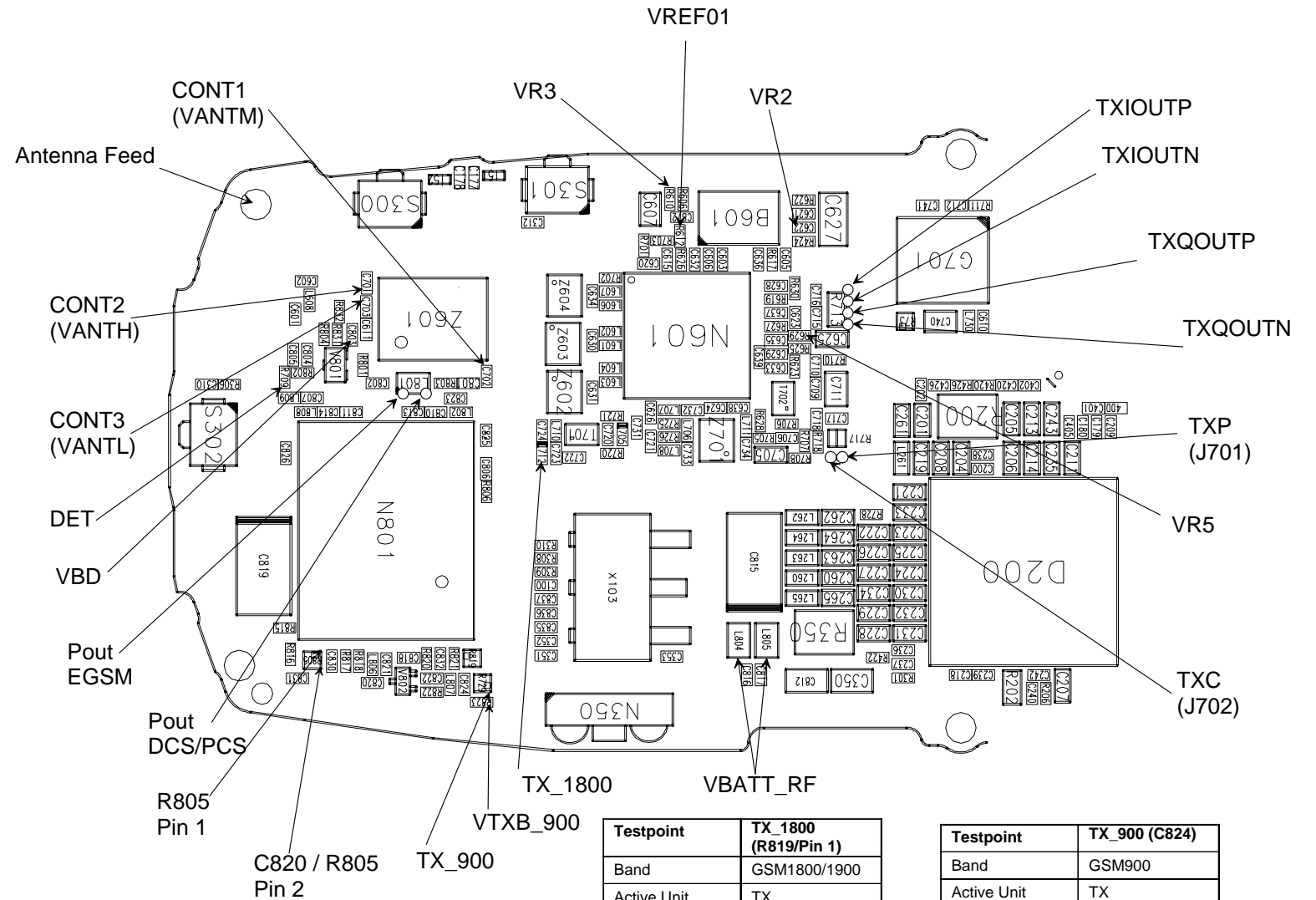

Testpoint	VBD (R832)
Band	GSM900/1800/1900
Active Unit	TX
Operation Mode	Burst
DC Offset	0 V
Graph	<p>VBD Detector Bias Voltage</p> <p>Upper curve: TXP-Signal (used as Trigger Signal) Lower curve: VBD voltage measured at R832</p>

Testpoint	TX_1800 (R819/Pin 1)
Band	GSM1800/1900
Active Unit	TX
Operation Mode	Burst
RX/TX Channel	700/661
Probed Power	Pref +1dBm

Testpoint	TX_900 (C824)
Band	GSM900
Active Unit	TX
Operation Mode	Burst
RX/TX Channel	37
Probed Power	Pref - 2.0dBm

Testpoint	VTXB_900
Band	GSM900
Active Unit	TX
Operation Mode	Burst
RX/TX Channel	37
Signal Amplitude	~ 2.7V
Graph	